

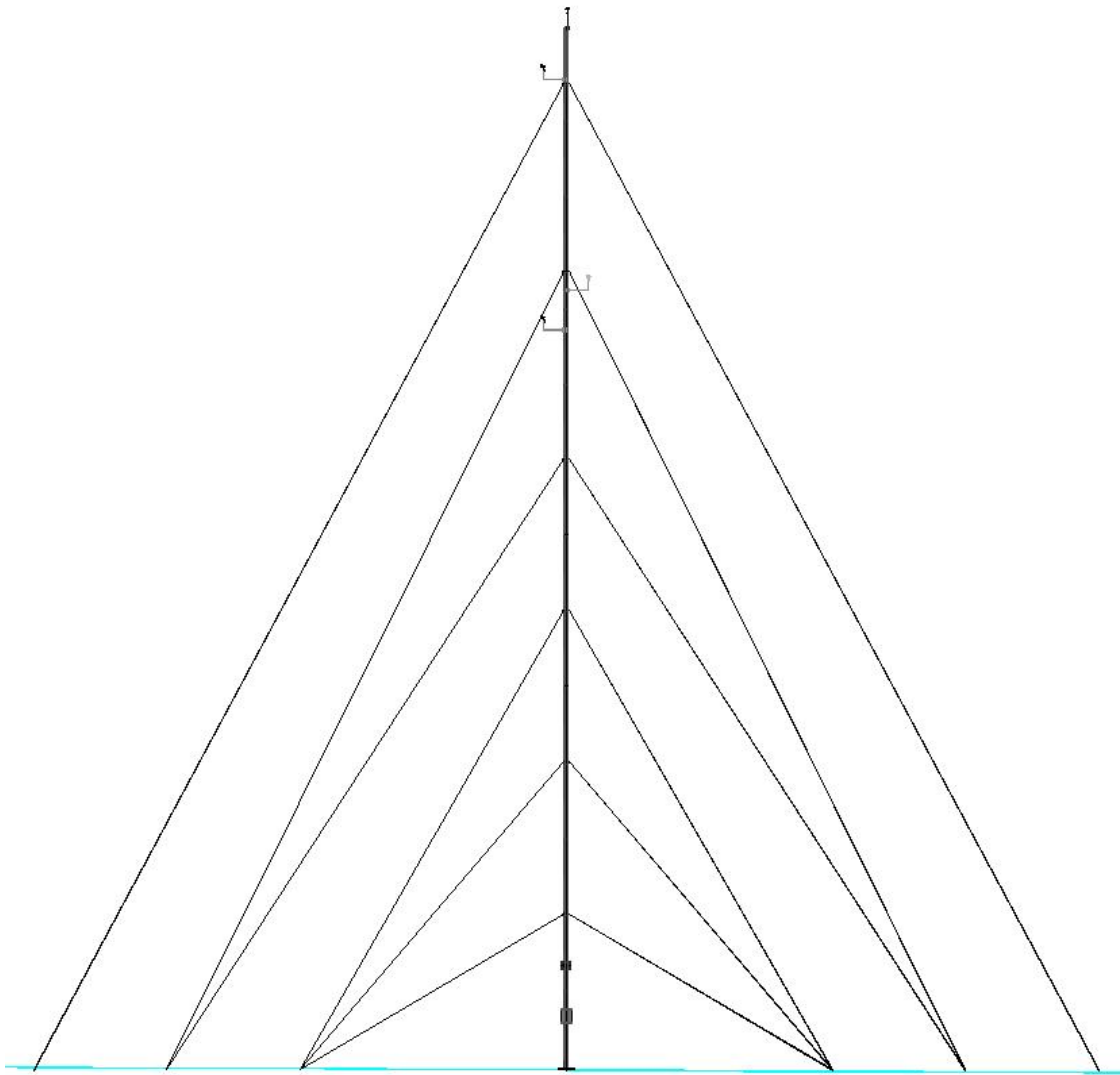

Enallaktiki Energiaki
renewable energy services and applications

40m -130mm Tubular Tower Technical Specifications



ENALLAKTIKI ENERGIAKI 2006©



Index

1	Contact Details.	3
2	Tubular Meteorological Towers.	4
2.1	Tubular Tower Versions.....	4
2.2	40m Tubular Tower Design limits.....	4
3	40m 130mm Tubular tower	5
3.1	Parts List	5
3.2	Parts description	5
3.2.1	Anchors.....	5
3.2.2	Anchor layout.	6
3.2.3	Tower assembly.....	7
3.2.4	Sensor Booms.....	8
3.2.5	Guy Wires.....	9
4	Safety Instructions.	10
4.1	Safety instructions during tower installation.....	10
4.2	Safety instructions during tower maintenance and service	12
4.3	Essential equipment	12

Photo Index

1.	Drawing: 40 m Mast anchoring layout.	7
2.	Figure: 45m Tower assembly and guy wire levels.....	8
3.	Drawing: Sensor side boom attached to the tubular tower.....	9



1 Contact Details.

Financial Siege

Name:	ENALLAKTIKI ENERGIAKI (I. PANOURGIAS – A. GEORGAKOPOULOS OE)
Financial Siege :	Street: 29, Ath. Eftaxia st, 350 02 - Amfiklia / Greece
Tax Office:	Amfiklia Tax Office
VAT:	80065332
Activities :	Renewable Energy Services and Applications

Company Offices

<i>Piraeus Offices:</i>	Aristotelous 10 str. P.C. 18535, Piraeus Tel. +30 210 4297728, +30 210 4297738 Fax: +30 210 4599686 e-mail: info@2en.gr
<i>Amfiklia Office:</i>	Ath Eftaxia 29 str. P.C. 35002, Amfiklia Tel. +30 22340 29150 Fax. +30 22340 29152
Web Site:	http://www.2en.gr

Personal contact Details

Georgakopoulos Athanasios	tel: +30 6944 185085	e- mail: tgeorg@2en.gr
Panourqias Ioannis	tel: +30 6973 208595	e-mail: ipanour@2en.gr

Important Notice

Meteo-tower installations should be calculated and carried out only by specialised professionals due to the associated responsibility they entail. The mounting instructions provided in this technical Specifications document are intended for information only. The data given does not, in any way, affect the responsibility of the manufacturer who only guarantees his own products, provided that they are used under normal conditions.

An installation project will need to be carried out for each individual installation. This project should consider the specific relevant requirements as well as the foundation calculation in accordance to the corresponding geotechnical study.

As part of our policy of continuous improvement we reserve the right to change the specification of this product at any time without any notice



2 Tubular Meteorological Towers.

2.1 Tubular Tower Versions

Many meteorological stations have been installed by Enallaktiki Energiaki during the past, at different sites in Greece, Turkey and Mongolia. The sites accessed by the company are of different topography, ground morphology, and weather conditions.

The company's field experience, including tests and studies regarding the proper choice of materials and dimensions, have led to the construction of wind towers of proven endurance and reliability under unfavourable climatic conditions.

This experience, combined with a strong scientific background has led us to design and produce a range of meteorological masts. The range, depending on the desired height of measurement and the diameter of the tube is as follows: (Tube thickness is 2.5mm)

Tubular Tower Versions



	Tube Diameter		
	70mm	130mm	152mm
Height (m) a.g.l	10	10	
		20	20
		30	30
		40	40
		45	

2.2 40m Tubular Tower Design limits.

The calculations have been carried out using the following design parameters:

- Tube diameter 130mm, thickness 2.5mm
- 40m high tubular tower
- Max allowed wind speed versus radial ice thickness

Radial Ice (mm)	Max allowed Wind speed
0	40
5	30
15	20
25	10
30	0



3 40m 130mm Tubular tower

3.1 Parts List

The 40 meter tubular tower 130mm tube diameter, 2.5mm wall thickness consists of the following parts:

Part description	Quantity
Galvanized 3-m long tubes of 130mm diameter with contraction	12
Galvanized 1.5-m long tubes of 130mm diameter with contraction	2
Galvanized 2.2-m long tubes of 130mm diameter without contraction	1
Guy wire sets	7
Base plate assembly	1
Tube joining hex head bolts M10X20	58
Base plate assembly hex head bolts M14X25	8
Hex head bolt joining base plate assembly with the mast assembly (M14X160)	1
Anchors	24
Wire rope clips	140
Eye links for wire ropes	28
Shackles	28
Guy wire tensioning devices	28
Technical Specifications sheet	1

The total weight of the tower assembly including the guy wires, the base plate assembly and the anchors is approximately 620kg.

The 9 meter gin pole consists of the following parts:

Part description	Quantity
Galvanized 3-m long tubes of 130mm diameter with contraction	3
Special wire rope adaptor	1
Hex head bolt joining base plate assembly with the gin pole (M14X160)	1
Hex head bolt joining wire rope adaptor with the gin pole (M14X160)	1
Tube joining hex head bolts M10X20	8
Ropes	2
Snap links	5



3.2 Parts description

3.2.1 Anchors

The anchors play a very important role in the stability and duration of an installation. Under difficult or extreme climatic conditions, such as icing, a well anchored mast, ensures an increased

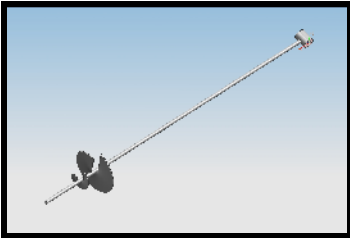

availability of meteorological data. Depending on the type of ground, different types of anchors are used according to the next table.

<i>Ground type</i>	<i>Anchor Photo</i>	<i>Anchor Type</i>
Earth with stones		1m Cornered steel
Compact Rock		1m Steel rod used on armoured concrete
Sandy ground		Propeller anchor: Steel rod equipped with circular plates propelling the anchor when rotating the rod

3.2.2 Anchor layout.

The 40 m – 130mm needs six anchoring points per direction. The suggested anchor distances from the mast position are 10m for guy wire levels No1 No2 and No3, 15m for guy wire level No4 and No5 and 20 meters for guy wire levels No6 and No7 which are described in the following schematics. It is suggested to use separate anchor for each guy wire.

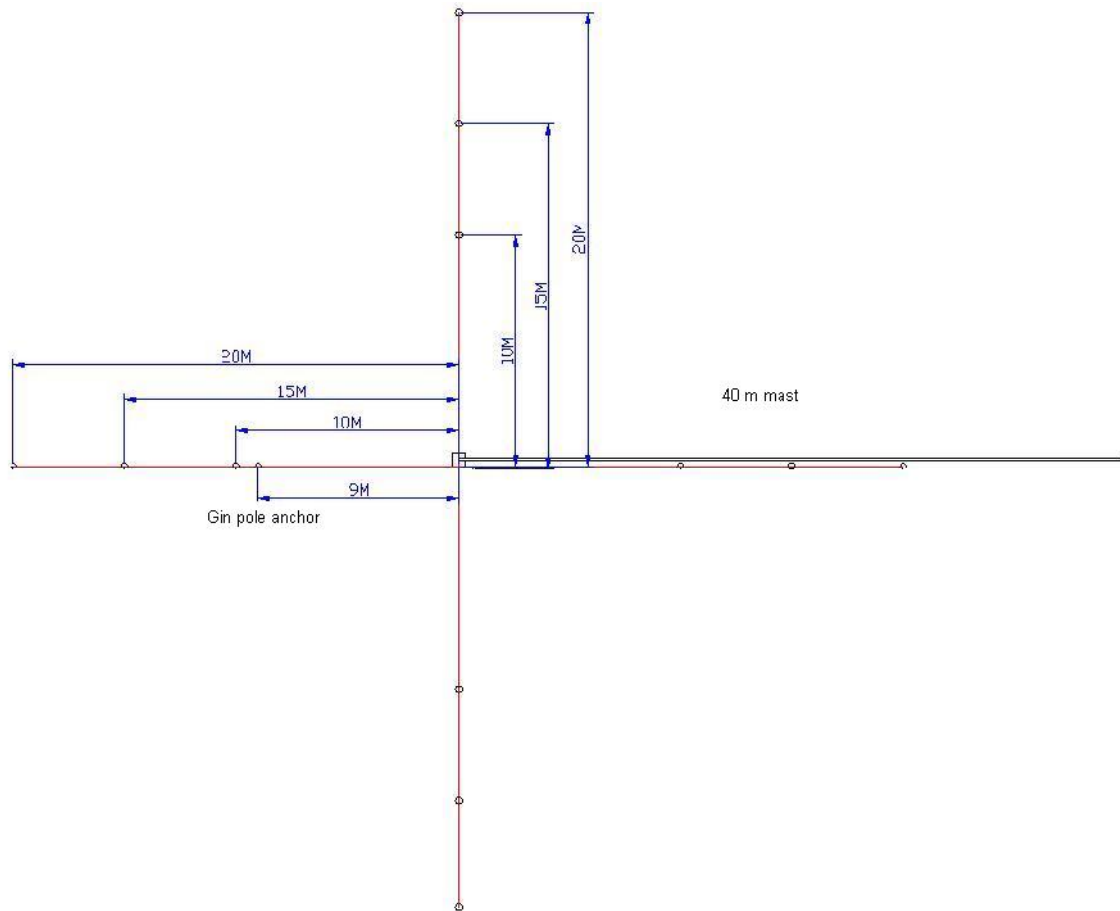

1. Drawing: 40 m Mast anchoring layout.

3.2.3 Tower assembly

The tower consists of twelve three meters long tubes two 1.5 meters long tubes and one 2.2 long tube. The 2.2 meter long tube (without contraction) is assembled at the top of the mast. All the other tubes are assembled according to the following figure.

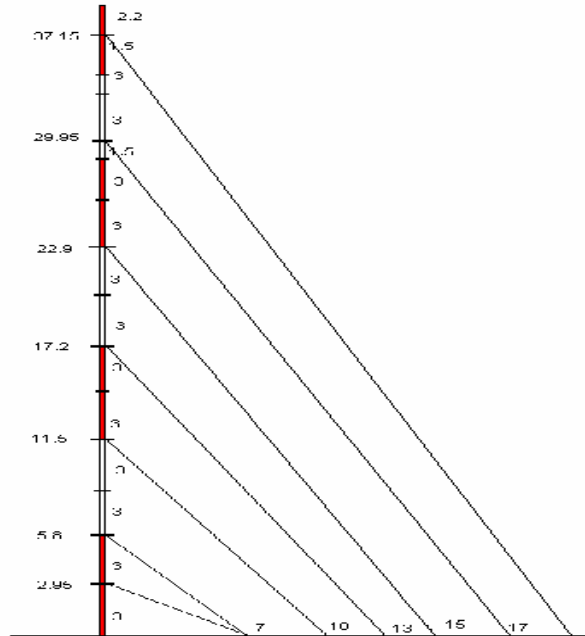

2. Figure: 45m Tower assembly and guy wire levels.

3.2.4 Sensor Booms

According to an iso-speed plot, with local speed normalised by free - field wind speed, of flow round mast of cylindrical cross section - analysis by two dimensional Navier-Stokes computations, a 1% deficit in wind speed is seen to occur at a value of d/R of approximately 0,17. For this level of distortion, a boom-mounted anemometer should be no closer than seven tower diameters from the centre of the tower. The corresponding figure of a 0,5% deficit is roughly 8,5 mast diameters. At the same time, the boom must remain stable, so that it does not oscillate.

According to this the sensor distance to the centre of the tower is 1210mm resulting in deficits of lower than 0.5%

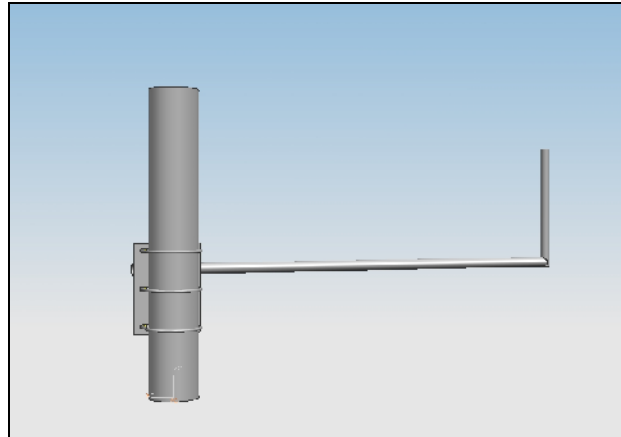

3. Drawing: Sensor side boom attached to the tubular tower

3.2.5 Guy Wires

The guy wires are of galvanized steel of a cross-section of 5.4 mm for the three first levels and 5.8 mm for the next four and a steel core type 7X7 of ultimate tensile force 30kN. Guy wires are mounted on galvanized plates of a thickness of 5 mm, supporting the mast in 7 different levels (2.95, 5.80, 11.5, 17.2, 22.9 και 29.95, 37.15m).



4 Safety Instructions.

All the company's employees have to be aware of the meteorological station installation safety instructions. All personnel working on site have been trained concerning health and safety in order to avoid any injury. There are several advice for things to avoid and take care of when installing or when maintaining and servicing a tower.

4.1 Safety instructions during tower installation



DO NOT

- Climb this tower.
- Erect tower within 1 ½ times the tower height of electric power lines.
- Erect tower within 1 ½ times the tower height of walkways, roads, or buildings.
- Permit unauthorized personnel onto the tower erection site while the tower is being installed.
- Raise or lower the tower on a day with high winds or gusty winds.
- Stand in line with, directly in front of, or behind any tensioned cable.



DO

- Determine the soil type at the specific site and install the correct anchors.
- Properly ground the tower electrically.
- Stand to the side of any tensioned cables.
- Thoroughly understand tower erection procedure before the installation begins. All crew members should read the Installation Manual before arriving at the installation site.



PLEASE STOP THE ERECTION PROCEDURE IF

- You are NOT familiar with erecting towers of this type, seek professional guidance.
- You have never installed a tubular guyed mast before. DO NOT attempt to install your 30 m, 40 or 45 m meteo tower without first having experienced the installation of a 10 m or 20 m Meteo tower, in order to become familiar with all installation procedures and concepts.
- You are not thoroughly familiar with all components of the tower, including all hardware and how all components function.
- Are not sure you can do it. Tall guyed towers are dangerous, and you or the members of your crew can be injured or killed.



PLEASE PAY EXTREME ATTENTION

- The tower side anchors alignment, should every next direction form a 90° angle. If such a positioning is not possible the maximum allowed deviation must not exceed 5°. Extra care should be placed during the stage where one or all of the following apply.
 - Anchor placement is not vertical to the tower.
 - Anchors are not at the same height between them nor with the tower base.
 - Side anchors and tower base are not aligned.
- During the rise the installation team must supervise and periodically loosen the side guy wires. **There is serious risk for tower collapse in case the guy wires are not appropriately balanced.** It is important to maintain the suitable wire strain during the rise. Too low strain may lead to a tower collapse in absence of retention. Too much strain may lead to tower failure, failure of the anchors or of the guy wires. It is necessary to always have a visible slack in the wire ropes. If the wire ropes are straight then they are too stretched.
- A stretched guy wire during rise, may cause serious strain on the tower and the anchors. These forces might cause extreme stress on the tower, leading to a tower collapse **putting in danger the installation team and nearby vehicles and equipment.**
- During the rise never leave the tower to decline more than 30cm from its imaginary line. In such a case it is necessary to adjust the guy wires in order to resume its initial straight alignment.
- 1-2 months after the installation date it is important to perform a tower alignment check, a visual check and adjustment of guy wires, given the fact that new wires loosen after their first stretching.
- At the beginning of winter (end of November – beginning of December) and definitely before first snow fall, it is imperative to perform a symmetrical stretching of the guy wires at every retention level. The stretching must be performed by professionals, since overstretching may lead the tower collapse. The greatest risk for the tower during winter months is for the guy wires to freeze, something which is dealt by stretching and whisking the wire ropes.
- Perform a tower state control after each heavy bad weather that may result to ice accumulation on the guy wires especially during the first year of tower installation.
- We remind you that this specific tower type is not suitable for installation to high altitude areas with heavy snow fall during winter months.



FOR YOUR OWN SAFETY



- During the installation use all the protection equipment to avoid injuries.
- Mandatory use of helmet and protection equipment
- Use special shoes, to protect feet from falling objects
- Use the appropriate clothing according to climate conditions.
- Follow the working instructions during heat waves during the summer months.
- The crew must be kept at a safety distance from the tower in the event of rain. There is serious electric shock danger from a thunder.
- Place special marks on the tower to warn for electric shock danger in order to avoid accidents.

4.2 Safety instructions during tower maintenance and service



DO NOT

- Climb on the tower
- Allow unprofessional personnel to approach and repair the tower
- Approach the tower during rainfall. Serious thunder-striking danger
- Park vehicles and install or store equipment at a distance smaller than 50 meters off the tower installation point.

4.3 Essential equipment

Every installation team, during station installation and maintenance must have the following equipment necessary to each worksite:

- Full pharmacy
- Car fire extinguisher
- GPS and compass
- Maps of the area
- Mobile phone for emergencies
- A list of emergency phone numbers