

STYLITIS-40/41

INSTALLATION  
GUIDE



## CONTENTS

|     |  |    |
|-----|--|----|
| 1.  | GENERAL.....                                 | 3  |
| 2.  | LOW-LEVEL AC ANEMOMETER NRG MAX#40. ....     | 5  |
| 3.  | REED ANEMOMETERS OR RAIN GAUGES. ....        | 7  |
| 4.  | FRIEDRICH 4034 ANEMOMETER. ....              | 9  |
| 5.  | VECTOR A100K, M, L2, LK, LM ANEMOMETER.....  | 10 |
| 6.  | THIES FIRST CLASS ANEMOMETER. ....           | 11 |
| 7.  | ANEMOMETER NRG #40H.....                     | 12 |
| 8.  | YOUNG 27106 PROPELLER ANEMOMETER. ....       | 13 |
| 9.  | WIND VANE NRG 200P .....                     | 15 |
| 10. | TEMPERATURE PT100. ....                      | 17 |
| 11. | TEMPERATURE NRG 110S.....                    | 19 |
| 12. | BAROMETRIC NRG BP20 .....                    | 21 |
| 13. | HUMIDITY NRG RH5 .....                       | 23 |
| 14. | TEMPERATURE-HUMIDITY DELTAOHM HD9009TR ..... | 25 |
| 15. | TEMPERATURE-HUMIDITY AMMONIT P6312 .....     | 27 |
| 16. | TEMPERATURE-HUMIDITY VAISALA HMP50 .....     | 29 |
| 17. | PYRANOMETER LICOR LI-200SA.....              | 31 |
| 18. | PYRANOMETER SKYE SKS-1110 .....              | 33 |
| 19. | 4~20MA TRANSMITTERS .....                    | 35 |
| 20. | SYMMETRON TILTOMETER.....                    | 37 |
| 21. | FLOW METERS.....                             | 39 |
| 22. | SYMMETRON TIMER FOR TC35T GSM MODEM .....    | 41 |
| 23. | BATTERY, SOLAR CELL AND TIMER.....           | 42 |
| 24. | DATA LOGGER MESSAGES .....                   | 46 |
| 25. | LOGGER QUICK CHECK.....                      | 47 |
| 26. | CONNECTION EXAMPLE .....                     | 48 |

Copyright © 1998-2009, The Symmetron Company.

Updated: May 2009.

No part of this publication may be reproduced, stored in a retrieval system, or transmitted, in any form by any means, without the prior written permission of Symmetron Company. **Information furnished by Symmetron is believed to be accurate and reliable; however, no responsibility is assumed for its use.** No license is granted by implication or otherwise.

Symmetron® is a registered trademark and Stylitis™ is a trademark of the Symmetron Company. All other trademarks belong to their respective owners.

---

### SYMMETRON ELECTRONIC APPLICATIONS

TEL: +30-210-603-4002 FAX: +30-210-603-4003

e-mail: [symmet@symmetron.gr](mailto:symmet@symmetron.gr) Web: <http://www.symmetron.gr/>

Made in Greece.

### REFERENCES:

- Stylitis-41 User's Manual.

# 1. GENERAL

## INPUTS:

Stylitis-41 is able to measure voltage, frequency and pulses (and current as an option). With suitable sensors it is also capable of measuring:

- Wind speed, direction and wind-turbine power curves
- Temperature, humidity, pressure.
- Solar radiation, rain height, water speed, etc.

The sensors' output must be within 0~5V and 0~3kHz.

## OUTPUTS:

The vane supply outputs (+5V PULSED) may be used for excitation, as they are capable of supplying up to a TOTAL of 25milliAmps with an accuracy of  $\pm 0.1\%$ .

One of the outputs (+VA PULSED) has selectable output voltage.

Similarly, the anemometer supply outputs (+5V FIXED) can supply up to a TOTAL of 10milliAmps with an accuracy of  $\pm 5\%$ . These outputs are not pulsed. Thus, the average current drawn from the battery is the same as the total Anemometer supply current.

## SERIAL PORT:

The Data logger comes equipped with one serial port. Communication speed fixed at 9600 baud with 8 data bits, 1 stop bit and no parity bit. The port is full duplex and may be one of the following:

### **RS232 (standard)**

DB9 Plug (Male). PIN 2: Transmit, PIN 3 Receive, PIN 5 Ground. To connect to a standard PC serial port a "straight" type cable is required, i.e. one, which connects pin 2 of one connector to pin 2 of the other, etc. Both cable connectors must be female.

### **RS485 (option)**

DB9 Plug (Male). PIN 2: Receive [-], PIN 7: Receive [+], PIN 3 Transmit [-], PIN 8 Transmit [+], PIN 5 Ground.

## QUICK SETUP:

Make sure you have gone through all of the following steps:

1. Connect sensors to the data logger.
2. Connect power supply (alkaline cells, lead-acid cells, etc.).
3. Depressing a key for more than one second activates the display, allowing interface with the user. Stylitis-41 automatically reverts to standby mode if there is no key action for 1 minute.
4. If PASSWORD protection has been activated, you are allowed 4 attempts to enter the correct one. Otherwise the instrument will lock and you must contact Symmetron to unlock it.
5. Setup time, date, site and math interval (10 minutes typical).
6. Using the menus, select the type of sensors and setup parameters (i.e. Slope/Offset for calibrated anemometers). Do not forget to set to **NOT USED** all unused channels.
7. Select **ENERGY SAVE MODE** from the **MODE** menu.
8. Data are stored in a memory card if you insert one; Otherwise they are stored in the internal buffer.
9. Select **ACQUISITION ON** to start data logging. It is recommended to always operate the data logger in **ACQUISITION ON**, unless you make changes to the setup. Selecting **ACQUISITION OFF** you automatically **delete** any stored data from the internal buffer (data are **not deleted** from a memory card).
10. Check the available logging space in days using **1>STATUS 3>CARD** or **1>STATUS 4>BUFFER**.

- To select a menu item use the corresponding numeric key.
- [ESC] goes one menu-level up and abandons changes.
- [ENTER] goes one menu-level up and saves changes.
- You can change parameters only when ACQUISITION is OFF.

## 2. LOW-LEVEL AC ANEMOMETER NRG MAX#40.

Other sinusoidal output sensors: YOUNG 05103 (for connections refer to instruction sheet).

### CONNECTION (MAX#40):

- Connect the first anemometer to screws 1 [COUNTER1] and 2 [GROUND] on the left screw terminal.
- Connect the second anemometer to screws 4 [COUNTER2] and 5 [GROUND] on the left screw terminal.
- Connect the third anemometer to screws 7 [COUNTER3] and 8 [GROUND] on the left screw terminal.
- Wire polarity does matter (see drawing). Typical wire size: 2 x 0,25 mm<sup>2</sup> (shielded cables are recommended). Connect the shield to the GROUND screw. Do not connect the shield to the anemometer.

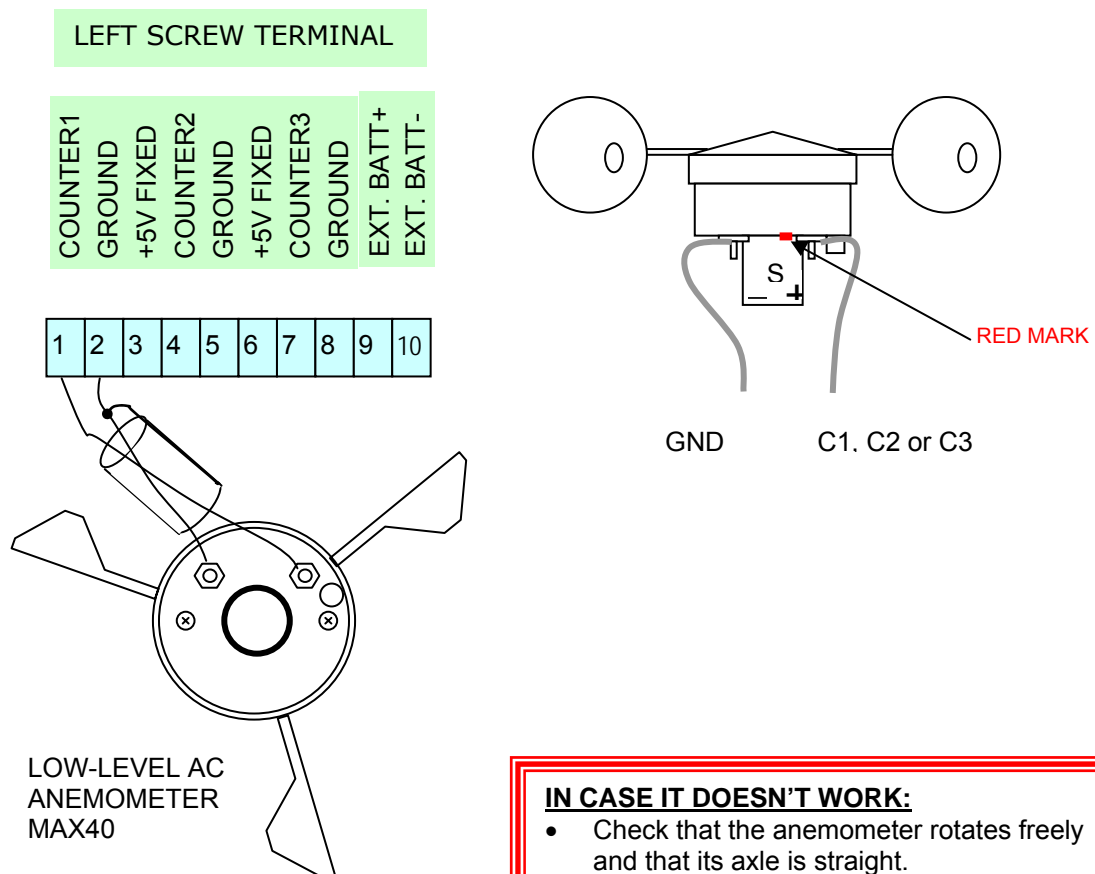

#### **IN CASE IT DOESN'T WORK:**

- Check that the anemometer rotates freely and that its axle is straight.
- With a multimeter check the resistance in the anemometer's terminals. It must be less than 1000Ω and greater than 400Ω.
- Rotate the anemometer and measure the AC voltage on its terminals; it should generate at least 200mV.

## SETUP:

Before changing the logger's setup select:  
**5> ACQ OFF** (press [5] and [ENTER].

After changing setup select:  
**5>ACQ ON** (press [5] and [ENTER])  
 to start acquisition (data logging).

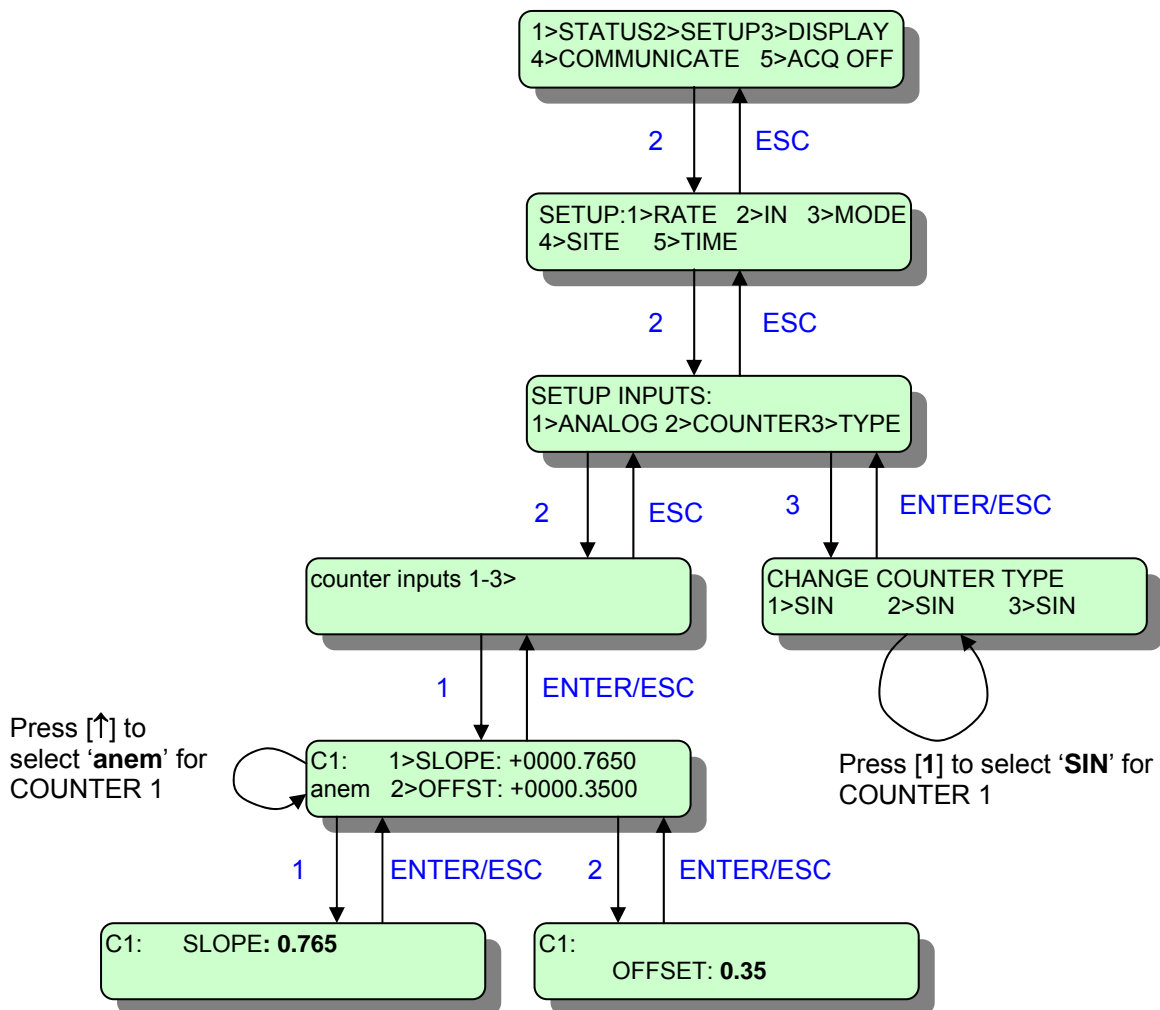

| ANEMOMETER  | SLOPE  | OFFSET |
|-------------|--------|--------|
| NRG MAX#40  | 0.7650 | 0.3500 |
| YOUNG 05103 | 0.0978 | 0.0000 |

NOTE: For calibrated anemometers enter the correct SLOPE and OFFSET values.

### 3. REED ANEMOMETERS OR RAIN GAUGES.

Switch-type sensors (reed): RISO P2546A, VECTOR A100R, FRIEDRICH 4091.1000

#### CONNECTION:

- Connect the first anemometer or rain gauge to screws 1 [COUNTER1] and 3 [+5V FIXED] on the left screw terminal.
- Connect the second anemometer or rain gauge to screws 4 [COUNTER2] and 3 [+5V FIXED] on the left screw terminal.
- Connect the third anemometer or rain gauge to screws 7 [COUNTER3] and 6 [+5V FIXED] on the left screw terminal.
- Wire polarity is irrelevant. Typical wire size: 2 x 0,25 mm<sup>2</sup> (shielded cables are recommended). Connect the shield to the GROUND screw and the metal body of the anemometer (if plastic, leave it unconnected).
- A 20kΩ pull-down resistor must be connected between a Counter input and Ground for each anemometer. Otherwise, the cable capacitance will not allow readings above a few meters/second.

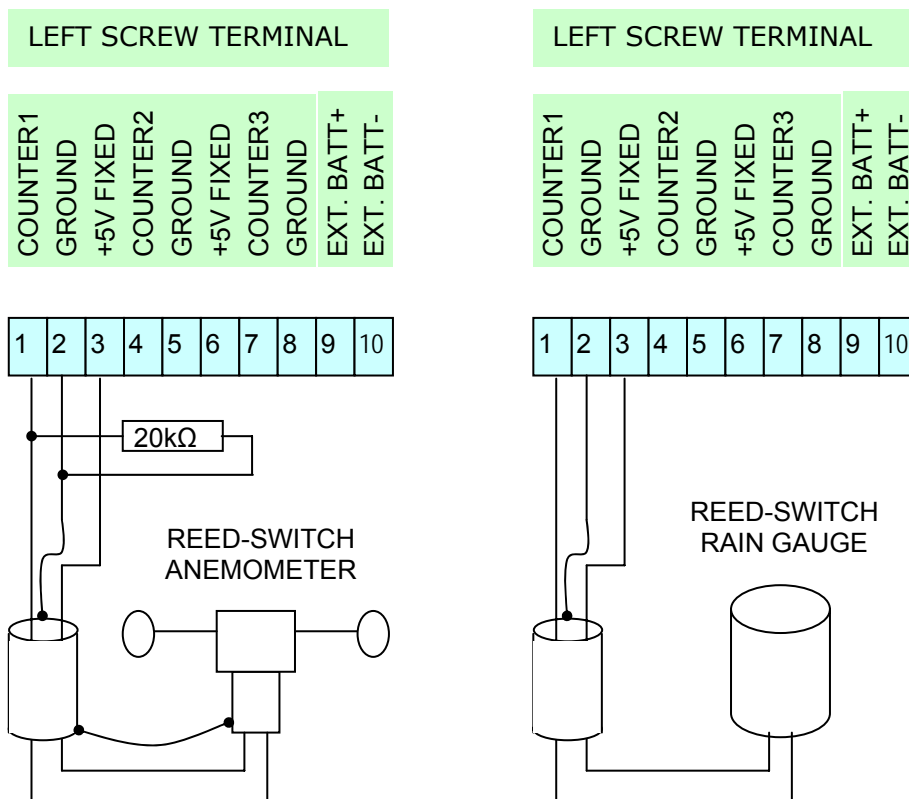

#### **IN CASE IT DOESN'T WORK:**

- Check that the anemometer or rain gauge rotates freely and that its axle is straight.
- With a multimeter check the resistance in the sensor's terminals: it should change from short circuit to open circuit while moving or rotating.

## SETUP:

Before changing the logger's setup select:  
**5> ACQ OFF** (press [5] and [ENTER]).

After changing setup select:  
**5>ACQ ON** (press [5] and [ENTER])  
 to start acquisition (data logging).

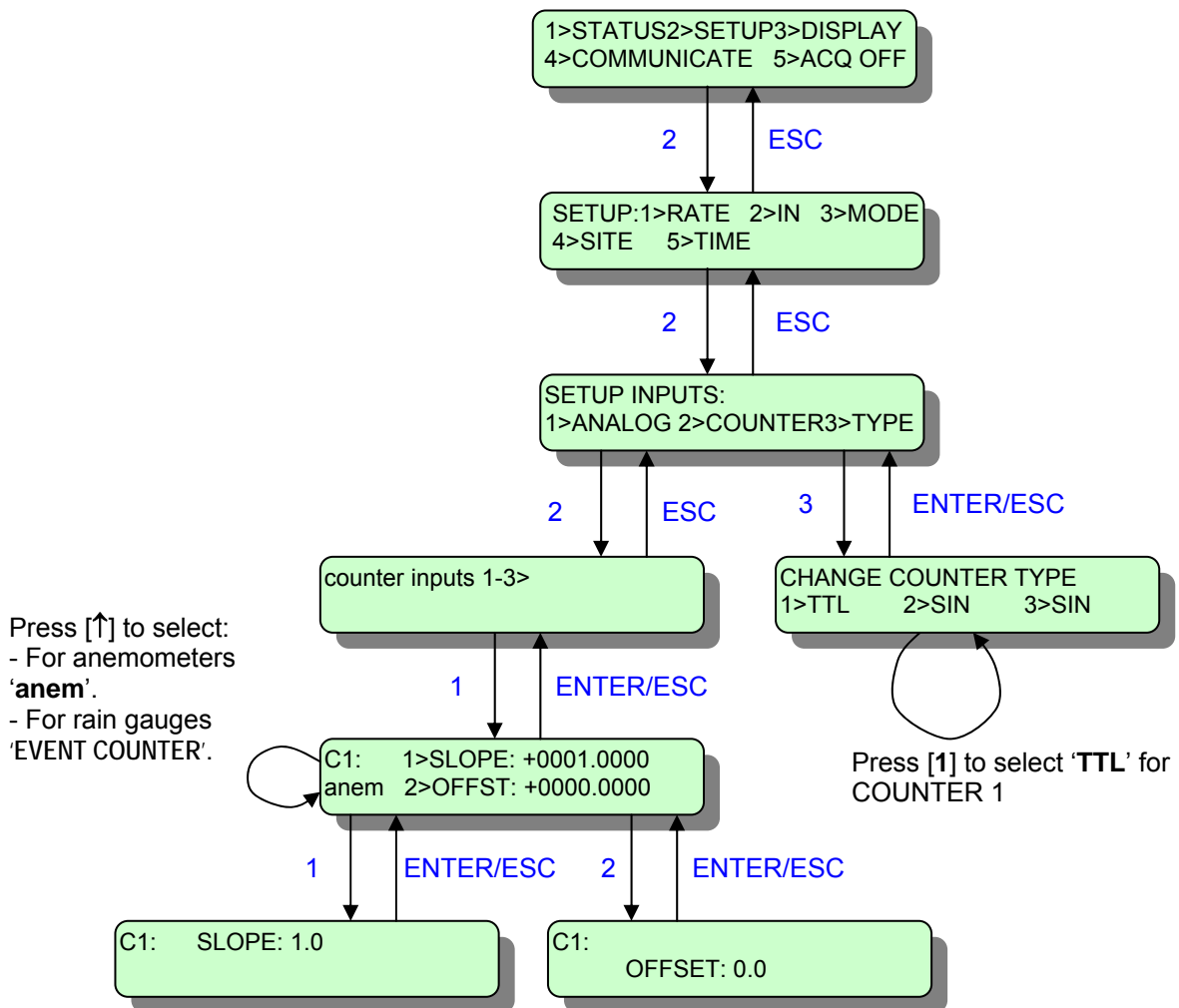

| ANEMOMETER               | SLOPE  | OFFSET |
|--------------------------|--------|--------|
| RISO P2546A              | 0.6201 | 0.2700 |
| VECTOR A100K             | 0.0515 | 0.0000 |
| VECTOR A100M             | 0.1000 | 0.0000 |
| VECTOR A100R             | 1.2500 | 0.0000 |
| FRIEDRICH 4034.0000/1000 | 0.1000 | 0.0000 |
| FRIEDRICH 4091.1000      | 0.3448 | 0.0000 |
| NRG #40H                 | 0.7650 | 0.3500 |
| THIES FIRST CLASS        | 0.0500 | 0.0000 |

NOTE1: For calibrated anemometers enter the corrected SLOPE and OFFSET values.

## 4. FRIEDRICH 4034 ANEMOMETER.

Optical disc-type sensor.

### CONNECTION:

- Connect the first anemometer to screws 1 [COUNTER1] and 2 [GROUND] on the left screw terminal.
- Connect the second anemometer to screws 4 [COUNTER2] and 5 [GROUND] on the left screw terminal.
- Connect the third anemometer to screws 7 [COUNTER3] and 8 [GROUND] on the left screw terminal.
- Wire polarity does matter (see drawing). Typical wire size: 2 x 0,25 mm<sup>2</sup> (shielded cables are recommended). Connect the shield to the GROUND screw and the metal body of the anemometer.
- A 20k $\Omega$  pull-up resistor must be connected between a Counter input and [+5V FIXED] for each anemometer. Otherwise, the cable capacitance will not allow readings above a few meters/second.

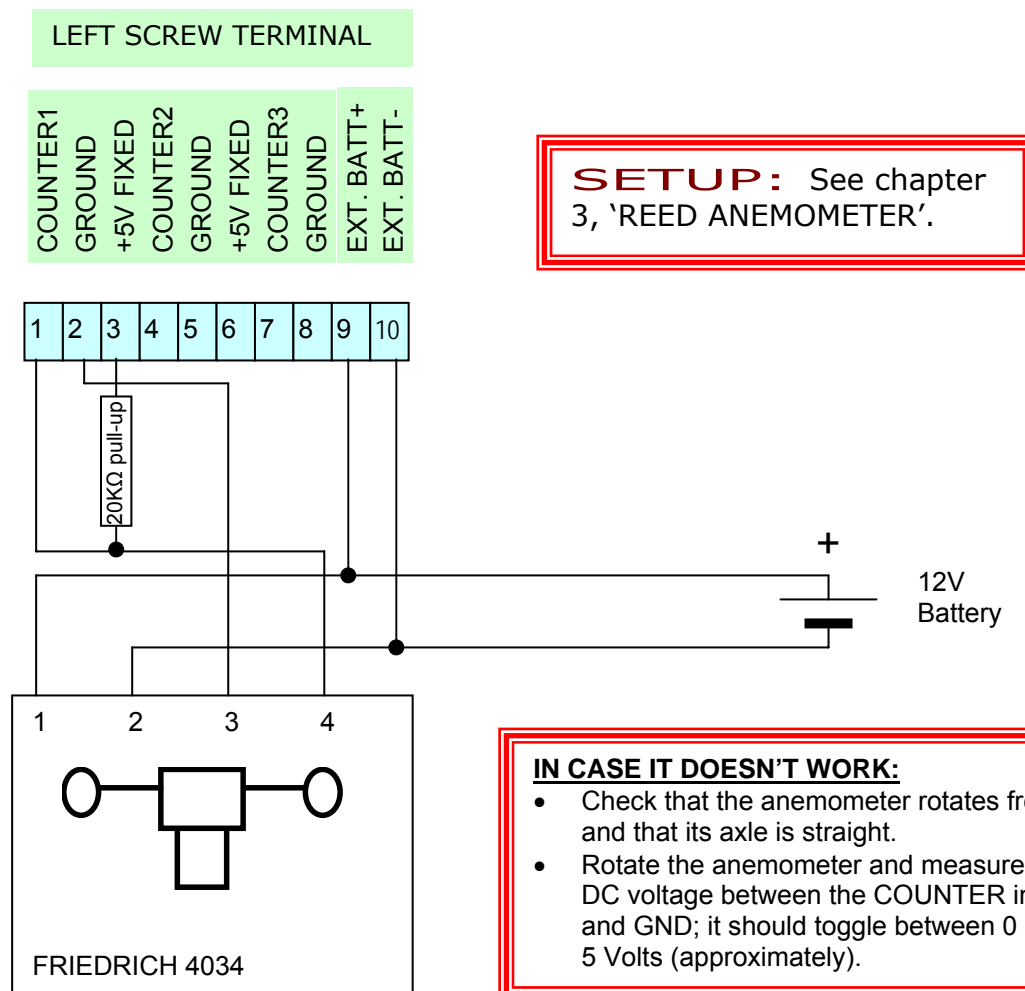

## 5. VECTOR A100K, M, L2, LK, LM ANEMOMETER.

Optical disk sensors

### CONNECTION:

- Connect the first anemometer to screws 1 [COUNTER1] and 2 [GROUND] on the left screw terminal.
- Connect the second anemometer to screws 4 [COUNTER2] and 5 [GROUND] on the left screw terminal.
- Connect the third anemometer to screws 7 [COUNTER3] and 8 [GROUND] on the left screw terminal.
- Wire polarity does matter (see drawing). Typical wire size: 2 x 0,25 mm<sup>2</sup> (shielded cables are recommended). Connect the shield to the GROUND screw and the metal body of the anemometer.

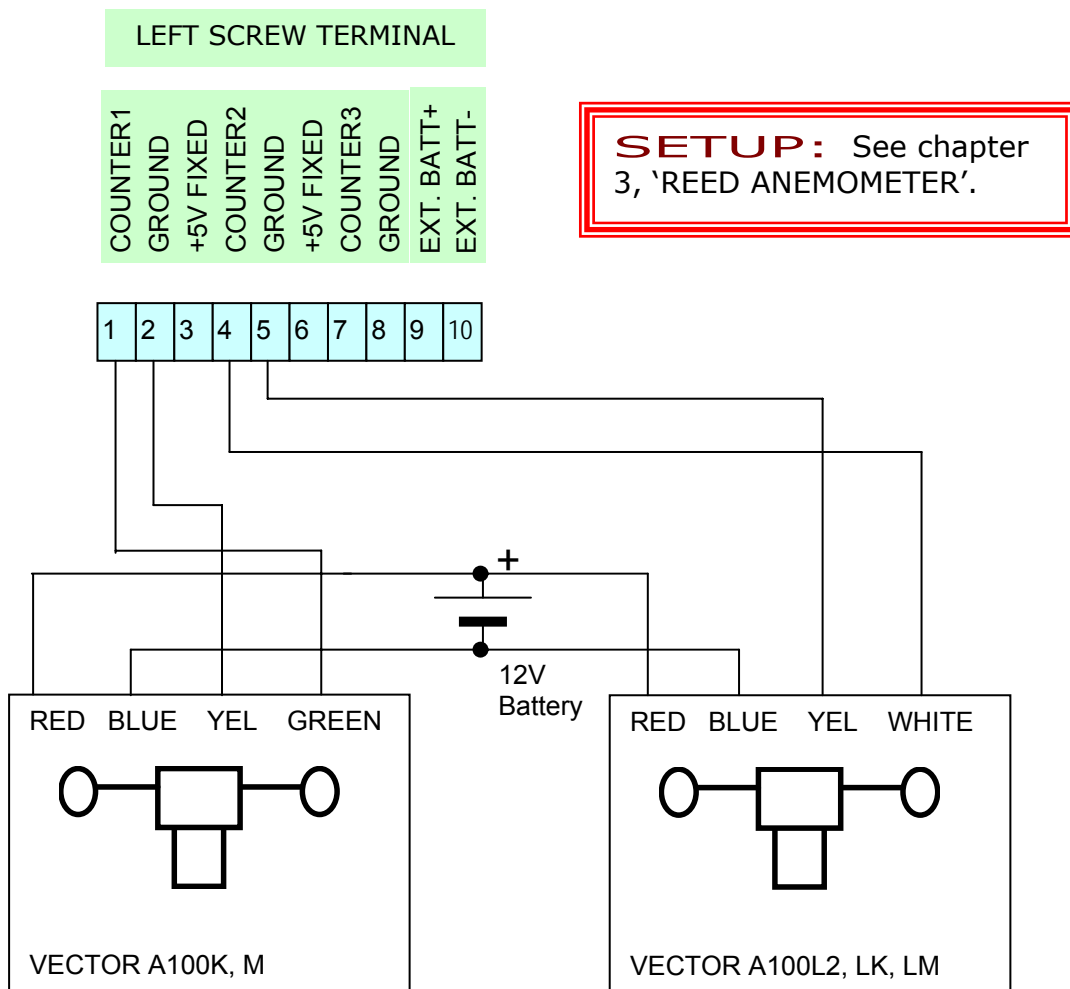

#### **IN CASE IT DOESN'T WORK:**

- Check that the anemometer rotates freely and that its axle is straight.
- Rotate the anemometer and measure the DC voltage between the COUNTER input and GND; it should toggle between 0 and 5 Volts (approximately).

## 6. THIES FIRST CLASS ANEMOMETER.

Optical disk type sensor.

### CONNECTION:

- Connect the first anemometer to screws 1 [COUNTER1] and 2 [GROUND] on the left screw terminal.
- Connect the second anemometer to screws 4 [COUNTER2] and 5 [GROUND] on the left screw terminal.
- Connect the third anemometer to screws 7 [COUNTER3] and 8 [GROUND] on the left screw terminal.
- Wire polarity does matter (see drawing). Typical wire size: 3 x 0,25 mm<sup>2</sup> (shielded cables are recommended). Connect the shield to the GROUND screw and the metal body of the anemometer.

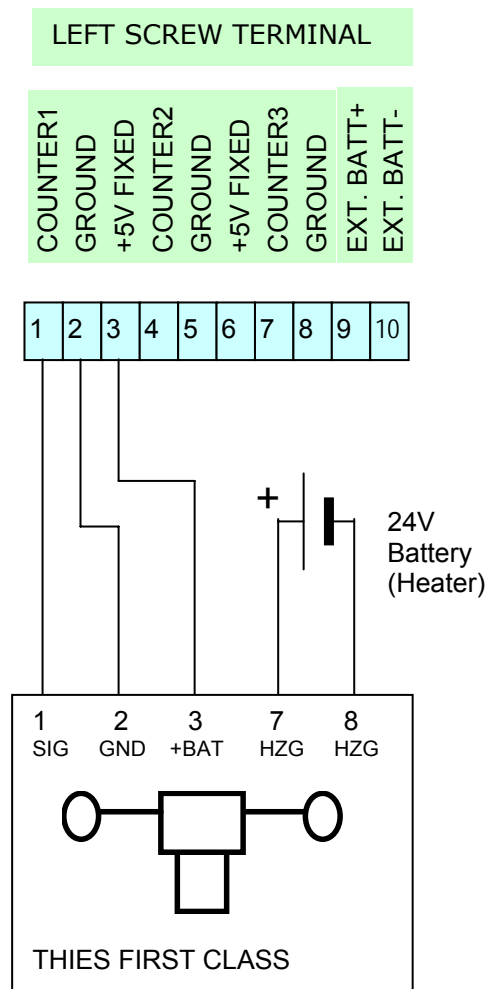

**SETUP:** See chapter 3, 'REED ANEMOMETER'.

#### **IN CASE IT DOESN'T WORK:**

- Check that the anemometer rotates freely and that its axle is straight.
- Rotate the anemometer and measure the DC voltage between the COUNTER input and GND; it should toggle between 0 and 5 Volts (approximately).

## 7. ANEMOMETER NRG #40H.

Hall-Effect type sensor.

### CONNECTION:

- Connect the first anemometer to screws 1 [COUNTER1] and 2 [GROUND] on the left screw terminal.
- Connect the second anemometer to screws 4 [COUNTER2] and 5 [GROUND] on the left screw terminal.
- Connect the third anemometer to screws 7 [COUNTER3] and 8 [GROUND] on the left screw terminal.
- Wire polarity does matter (see drawing). Typical wire size: 3 x 0,25 mm<sup>2</sup> (shielded cables are recommended). Connect the shield to the GROUND screw. Do not connect the shield to the anemometer.
- A 18~22 kΩ pull-up resistor must be connected between Counter input and [+5V FIXED] for each anemometer. Otherwise, the anemometer will not work.

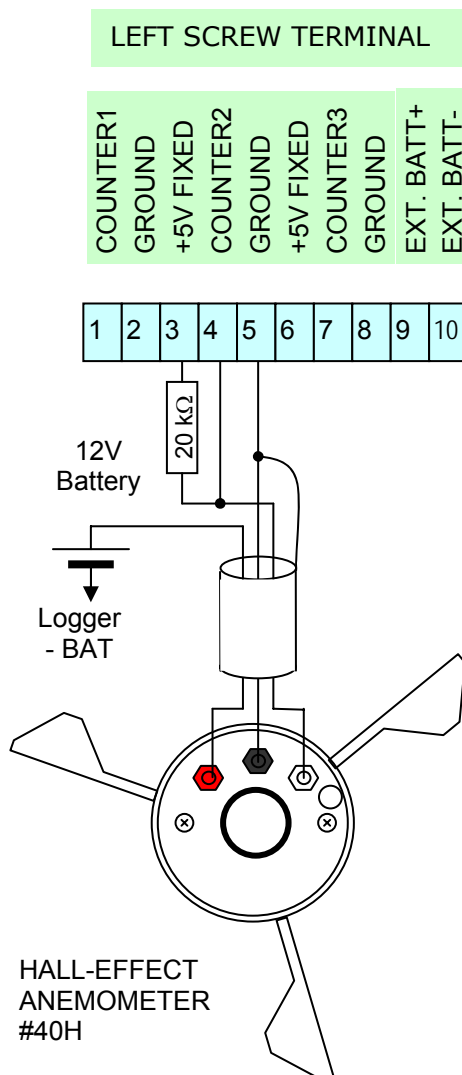

**SETUP:** See chapter 3, 'REED ANEMOMETER'.

#### **IN CASE IT DOESN'T WORK:**

- Check that the anemometer rotates freely and that its axle is straight.
- Rotate the anemometer and measure the DC voltage between the COUNTER input and GND; it should toggle between 0 and 5 Volts (approximately).

## 8. YOUNG 27106 PROPELLER ANEMOMETER.

Tacho-generator type sensor.

### CONNECTION:

- Connect the first anemometer to screws 1 [+5V PULSED], 2 [ANALOG1] and 3 [GROUND] on the right screw terminal.
- Connect the second anemometer to screws 4 [+5V PULSED], 5 [ANALOG2] and 6 [GROUND] on the right screw terminal.
- Connect the third anemometer to screws 7 [+VA PULSED], 8 [ANALOG3] and 9 [GROUND] on the right screw terminal. CAUTION: make sure that position 7 [+VA PULSED] generates +5V and not +12V or +18V!
- Wire polarity does matter (see drawing). Typical wire size: 2 x 0,25 mm<sup>2</sup> (shielded cables are recommended). Connect the shield to the GROUND screw and the metal body of the anemometer.

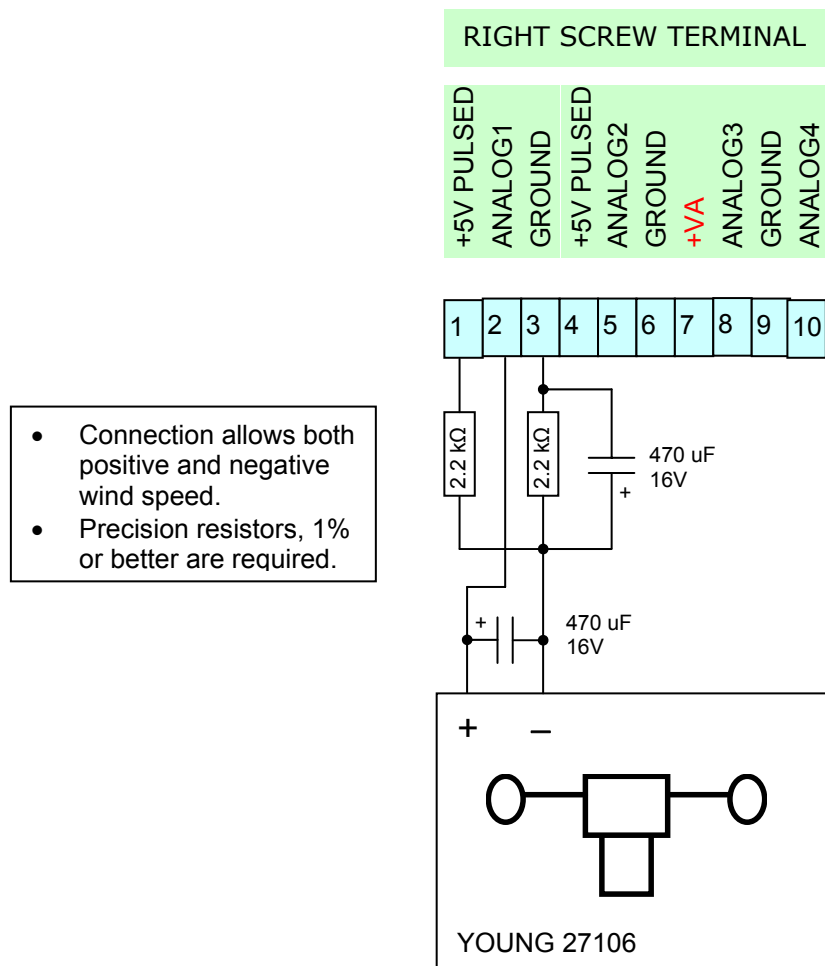

#### **IN CASE IT DOESN'T WORK:**

- Check that the anemometer rotates freely and that its axle is straight.
- With a multimeter check the voltage between [+] and [-] wires: at a wind speed of 4.5 m/s, it should be about 0.25 V DC.

## SETUP:

Before changing the logger's setup select:  
**5> ACQ OFF** (press [5] and [ENTER]).

After changing setup select:  
**5> ACQ ON** (press [5] and [ENTER])

to start acquisition (data logging).

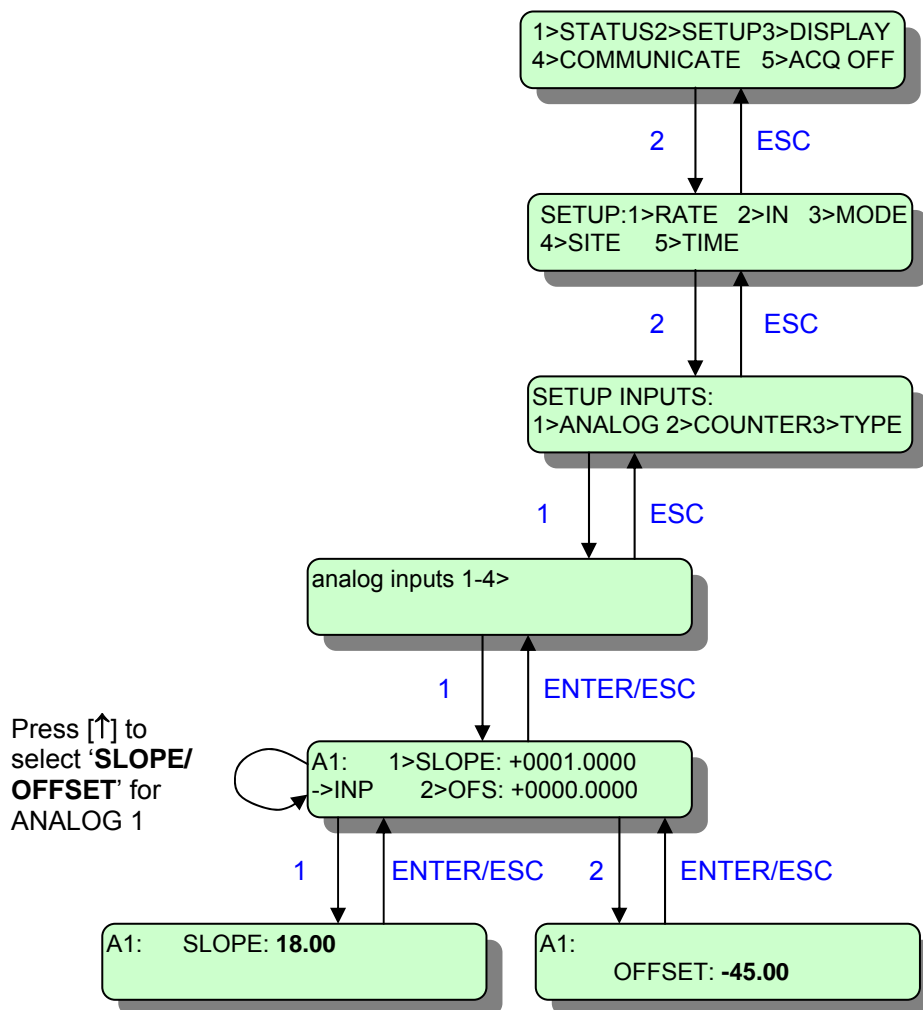

Coefficients for conversion to Meters per Second.

## 9. WIND VANE NRG 200P

Other potentiometric sensors with resistance 1K $\Omega$  or greater:  
YOUNG 05103 (for connections refer to instruction sheet).

### CONNECTION:

- Connect the first wind vane to screws 1 [+5V PULSED], 2 [ANALOG1] and 3 [GROUND] on the right screw terminal.
- Connect the second wind vane to screws 4 [+5V PULSED], 5 [ANALOG2] and 6 [GROUND] on the right screw terminal.
- Connect the third wind vane to screws 7 [+VA PULSED], 8 [ANALOG3] and 9 [GROUND] on the right screw terminal. CAUTION: make sure that position 7 [+VA PULSED] generates +5V and not +12V or +18V!
- Wire polarity does matter (see drawing): The **RED** screw of the wind vane connects to +5V, the middle screw of the wind vane with an ANALOG position and the last screw of the wind vane to a GROUND position. Typical wire size: 2 x 0,25 mm<sup>2</sup> (shielded cables are recommended). If a shield exists connect it to the GROUND screw. Do not connect the shield to the wind vane.
- Be careful not to short-circuit the shield with any of the wind vane screws. Wrong connections may damage the wind vane!

**IN CASE IT DOESN'T WORK:**

- Check that the wind vane rotates freely and that its axle is straight.
- With a multimeter check the resistance between the wind vane's most far-apart terminals. It must be about 10k $\Omega$ .
- Rotate the wind vane and measure the resistance from the center screw to one of the other screws; it should change from 0 $\Omega$  to about 10k $\Omega$ .

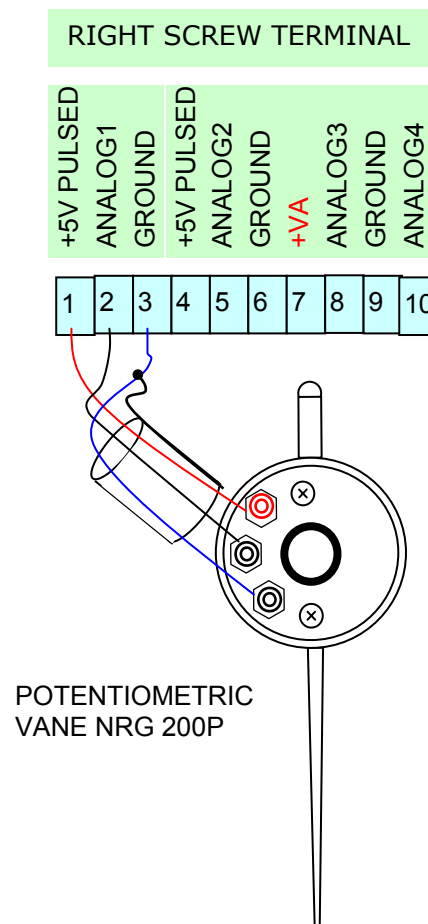

## SETUP:

Before changing the logger's setup select:  
**5> ACQ OFF** (press [5] and [ENTER]).

After changing setup select:  
**5>ACQ ON** (press [5] and [ENTER])  
to start acquisition (data logging).

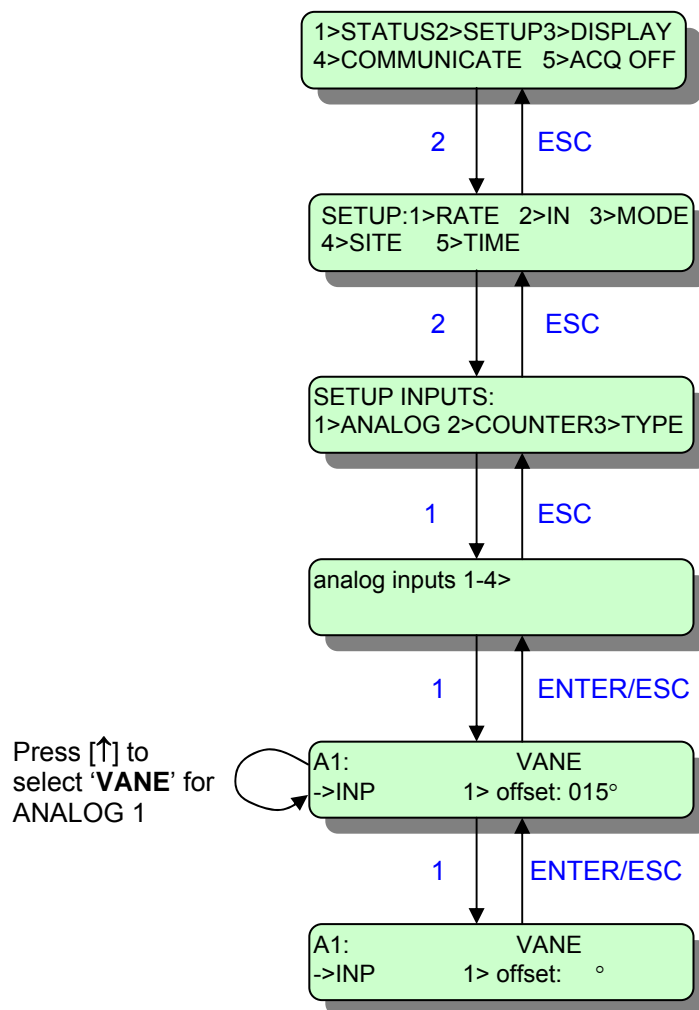

Enter the vane offset for direction measurement in degrees (0~359).  
For instance, if the vane "zero" mark is placed 30 east then you  
enter 30 as offset; if it is placed 30 West you enter 330 (=360-30) as  
offset.

## 10. TEMPERATURE PT100.

Platinum sensors (RTD), 100Ω resistance at 0°C: VECTOR T351, etc.  
Temperature range: -50°C ~ +55°C.

### CONNECTION:

- Connect the first PT100 sensor and a 350Ω / 0.1%, 3ppm resistor, to screws 1 [+5V PULSED], 2 [ANALOG1] and 3 [GROUND] on the right screw terminal (see drawing).
- Connect the second PT100 sensor and a 350Ω / 0.1%, 3ppm resistor, to screws 4 [+5V PULSED], 5 [ANALOG2] and 6 [GROUND] on the right screw terminal.
- Connect the third PT100 sensor and a 350Ω / 0.1%, 3ppm resistor, to screws 7 [+VA PULSED], 8 [ANALOG3] and 9 [GROUND] on the right screw terminal. CAUTION: make sure that position 7 [+VA PULSED] generates +5V and not +12V or +18V!
- If a PT1000 sensor is used replace the external resistor with a 3.5kΩ, 0.1%, 3ppm type. Wire sizes in the following table can then be reduced to one tenth (1/10).
- Wire polarity is irrelevant. Wire size according to connection distance (shielded cables are recommended):

| CABLE LENGTH<br>meters | WIRE SIZE<br>mm <sup>2</sup> (PT100) |
|------------------------|--------------------------------------|
| Up to 1                | 2x0,35                               |
| Up to 2                | 2x0,50                               |
| Up to 3                | 2x0,75                               |
| Up to 4                | 2x1                                  |
| Up to 5                | 2x1,5                                |
| Up to 10               | 2x2,5                                |
| Up to 20               | 2x4                                  |

If a shield exists connect it to the GROUND screw. Do not connect the shield to the PT100 sensor.

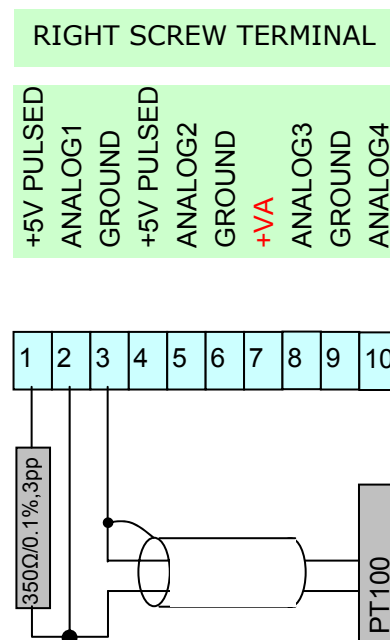

#### **IN CASE IT DOESN'T WORK:**

- The data logger must be in 'ENERGY SAVE' mode. Otherwise, the sensor will heat-up and measure a little higher than correct.
- With the sensor disconnected from the logger, use a multimeter to check the resistance between the sensor's terminals. At ambient temperature (23°C) it should be about 110Ω.

## SETUP:

Before changing the logger's setup select:  
5> **ACQ OFF** (press [5] and [ENTER]).

After changing setup select:  
5>**ACQ ON** (press [5] and [ENTER])

to start acquisition (data logging).

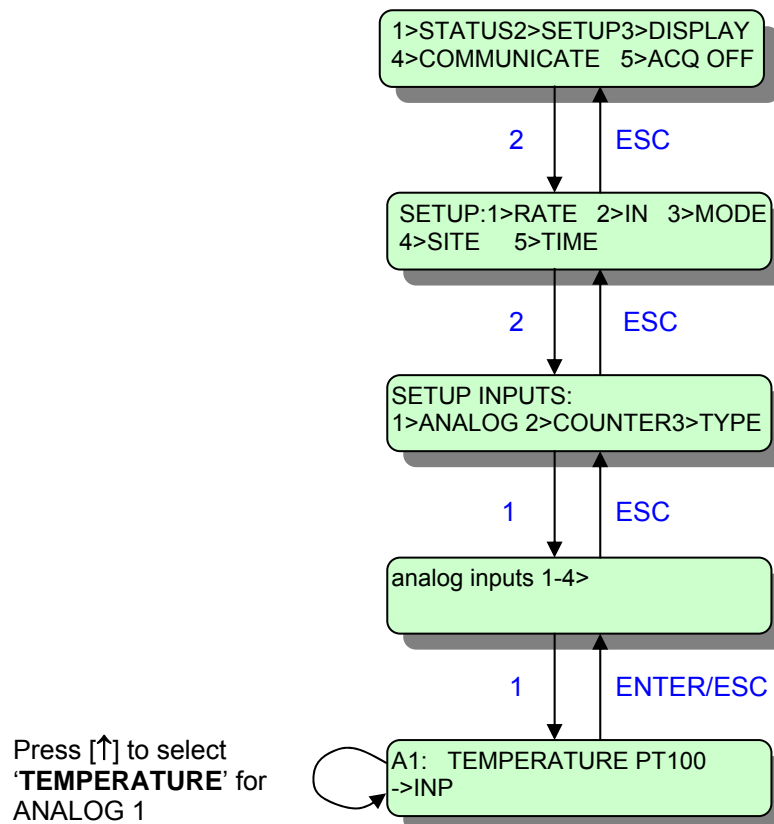

## 11. TEMPERATURE NRG 110S

### CONNECTION:

- Connect the first temperature sensor to screws 1 [+5V PULSED], 2 [ANALOG1] and 3 [GROUND on the right screw terminal.
- Connect the second temperature sensor to screws 4 [+5V PULSED], 5 [ANALOG2] and 6 [GROUND] on the right screw terminal.
- Connect the third temperature sensor to screws 7 [+VA PULSED], 8 [ANALOG3] and 9 [GROUND] on the right screw terminal. CAUTION: make sure that position 7 [+VA PULSED] generates +5V and not +12V or +18V!
- Wire polarity does matter (see drawing): The red wire of the sensor connects to [+5V PULSED], the white wire of the sensor connects to an ANALOG position and the black wire of the sensor, together with the sensor's cable shield to a GROUND position. Typical wire size: 2 x 0,25 mm<sup>2</sup> (shielded cables are recommended).

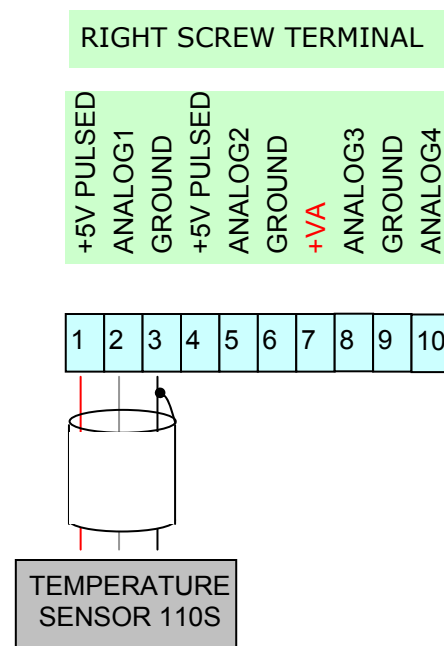

#### **IN CASE IT DOESN'T WORK:**

- With the sensor connected to the logger, select from the main menu: **SETUP>MODE>CONTINUOUS>**[ENTER]
- With a multimeter check the voltage between the white and black wire: at ambient temperature (23°C) it should be about 2V.

## SETUP:

Before changing the logger's setup select:  
**5> ACQ OFF** (press [5] and [ENTER]).

After changing setup select:  
**5>ACQ ON** (press [5] and [ENTER])

to start acquisition (data logging).

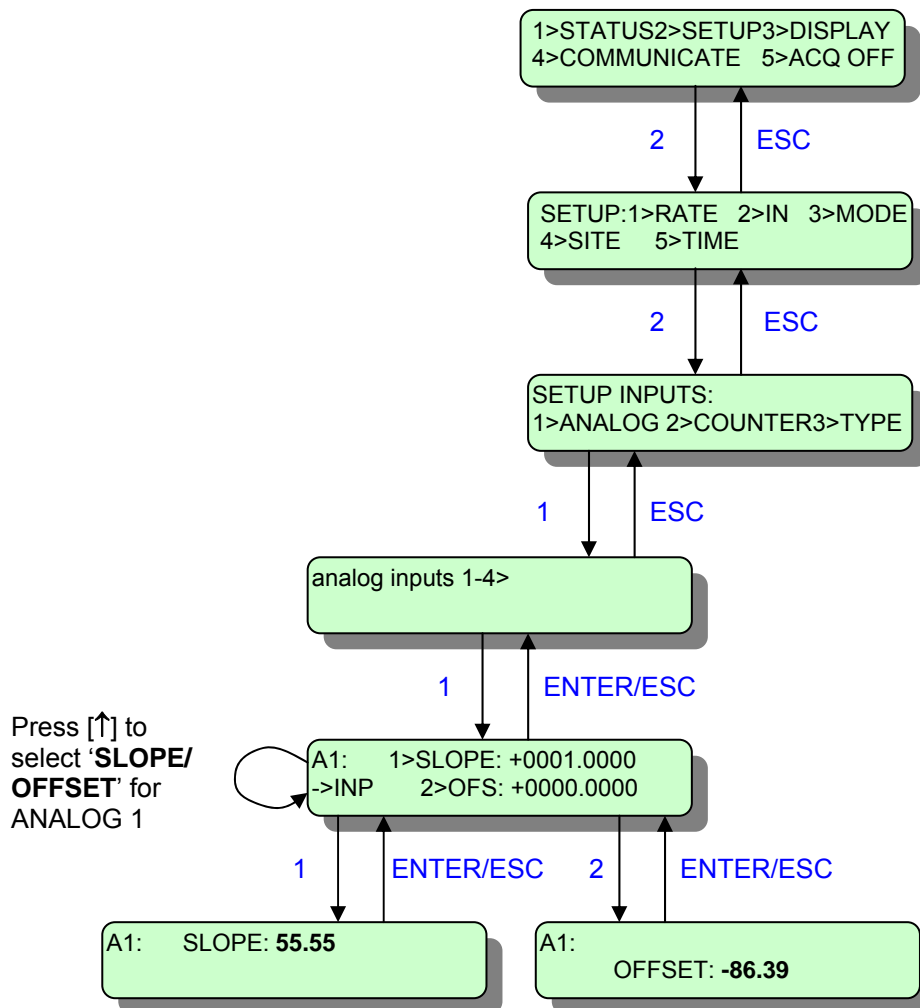

- Coefficients for Celsius degrees:  
SLOPE: 55.55, OFFSET: -86.39
- Coefficients for Fahrenheit degrees:  
SLOPE: 100, OFFSET: -123.5

## 12. BAROMETRIC NRG BP20

### CONNECTION:

- Connect the first sensor to screws 2 [ANALOG1] and 3 [GROUND] της on the right screw terminal.
- Connect the second sensor to screws 5 [ANALOG2] και 6 [GROUND] on the right screw terminal.
- Connect the third sensor to screws 8 [ANALOG3] και 9 [GROUND] on the right screw terminal.
- Wire polarity does matter (see drawing): The **red** wire of the sensor connects to an external +7V ~ +35VDC power source (typically a 12V lead-acid battery). The **white** wire of the sensor connects to an ANALOG position and the black wire of the sensor, together with the sensor's cable shield to a GROUND position. Typical wire size: 2 x 0,25 mm<sup>2</sup> (shielded cables are recommended).

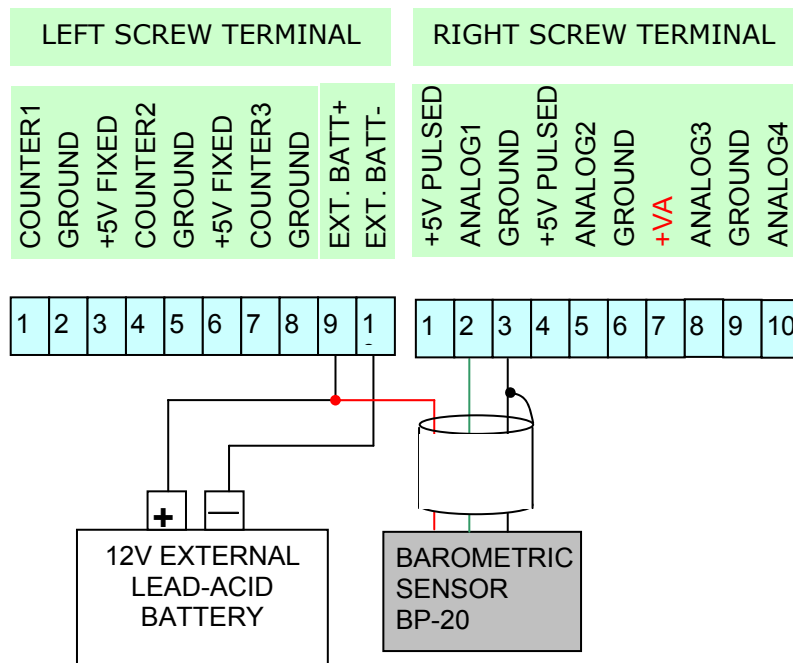

#### **IN CASE IT DOESN'T WORK:**

- Connect the sensor to the battery.
- With a multimeter check the voltage between the green and black wire: it should be about 4V.

## SETUP:

Before changing the logger's setup select:  
**5> ACQ OFF** (press [5] and [ENTER]).

After changing setup select:  
**5> ACQ ON** (press [5] and [ENTER])

to start acquisition (data logging).

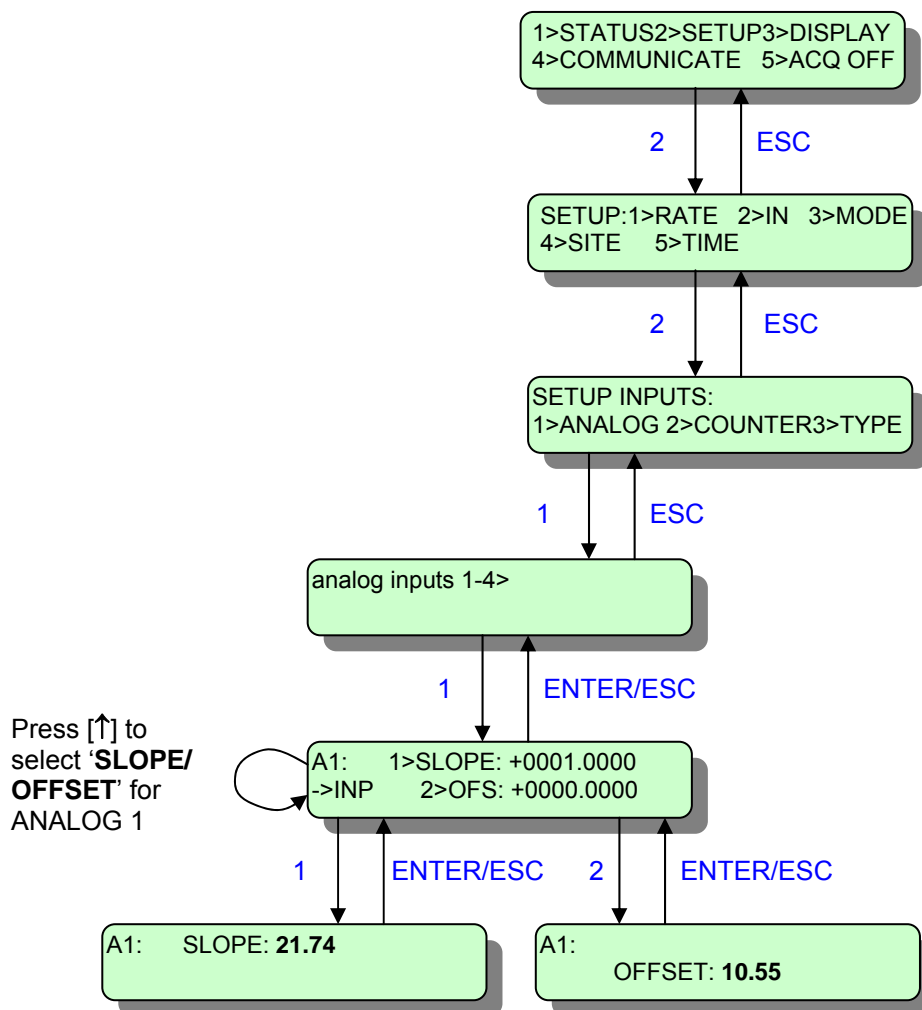

Coefficients for conversion to kPa  
 For calibrated sensors enter the correct  
 SLOPE and OFFSET values.

## 13. HUMIDITY NRG RH5

### CONNECTION:

- Connect the first sensor to screws 2 [ANALOG1] and 3 [GROUND] της on the right screw terminal.
- Connect the second sensor to screws 5 [ANALOG2] και 6 [GROUND] on the right screw terminal.
- Connect the third sensor to screws 8 [ANALOG3] και 9 [GROUND] on the right screw terminal.
- Wire polarity does matter (see drawing): The **red** wire of the sensor connects to an external +10V ~ +36VDC power source (typically a 12V lead-acid battery). The **white** wire of the sensor connects to an ANALOG position and the black wire of the sensor, together with the sensor's cable shield to a GROUND position. Typical wire size: 2 x 0,25 mm<sup>2</sup> (shielded cables are recommended).

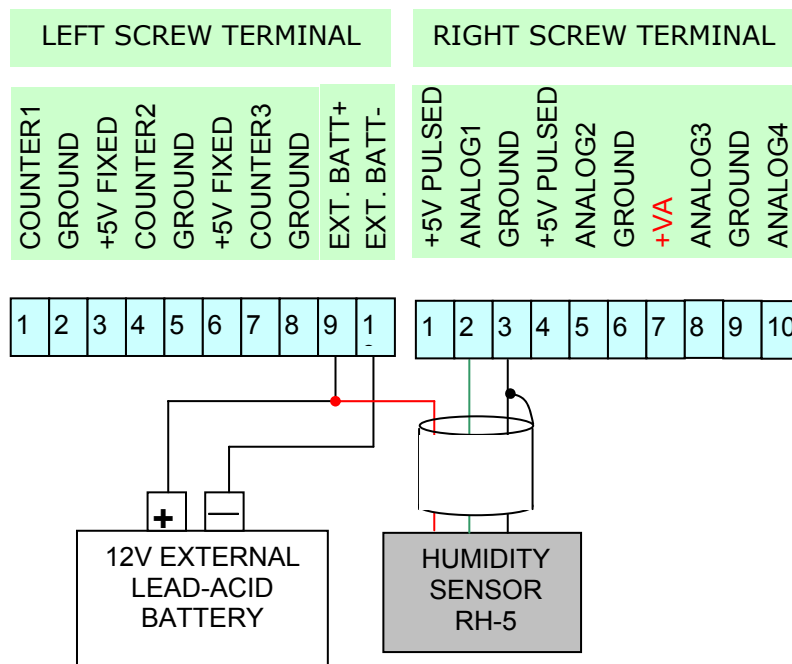

#### **IN CASE IT DOESN'T WORK:**

- Connect the sensor to the battery.
- With a multimeter check the voltage between the green and black wire: for 60% humidity it should read about 3V.

## ΠΩΣ ΡΥΘΜΙΖΕΤΑΙ:

Before changing the logger's setup select:  
**5> ACQ OFF** (press [5] and [ENTER]).

After changing setup select:  
**5>ACQ ON** (press [5] and [ENTER])

to start acquisition (data logging).

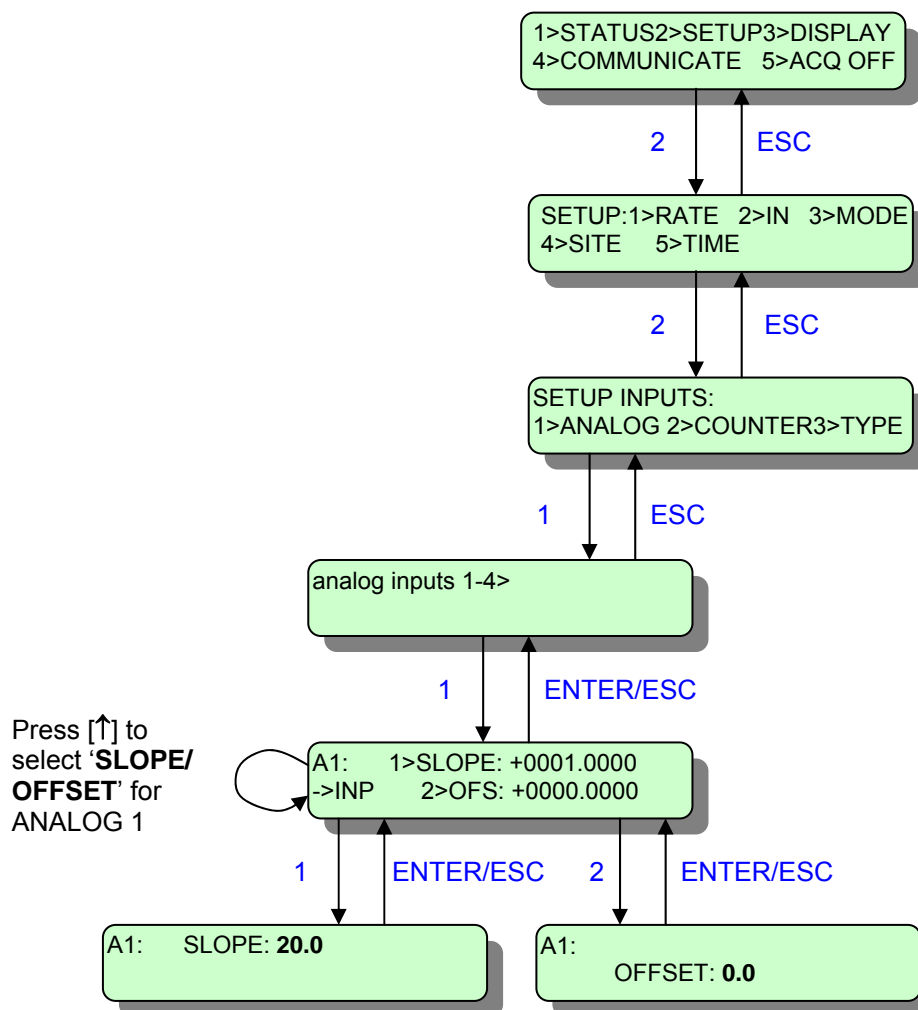

Coefficients for conversion to percent relative humidity.  
 For calibrated sensors enter the correct SLOPE και OFFSET values.

## 14. TEMPERATURE-HUMIDITY DeltaOhm HD9009TR

### CONNECTION:

- Connect the first sensor to screws 2 [ANALOG1], 5 [ANALOG2] and 3 [GROUND] on the right screw terminal.
- Connect the second sensor to screws 8 [ANALOG3], 10 [ANALOG4] και 9 [GROUND] on the right screw terminal.
- Wire polarity does matter (see drawing): The sensor connects to an external +7V ~ +30VDC power source (typically a 12V lead-acid battery). The sensor GROUND together with the cable shield connects to a logger GROUND position. Typical wire size: 4 x 0,25 mm<sup>2</sup> (shielded cables are recommended).

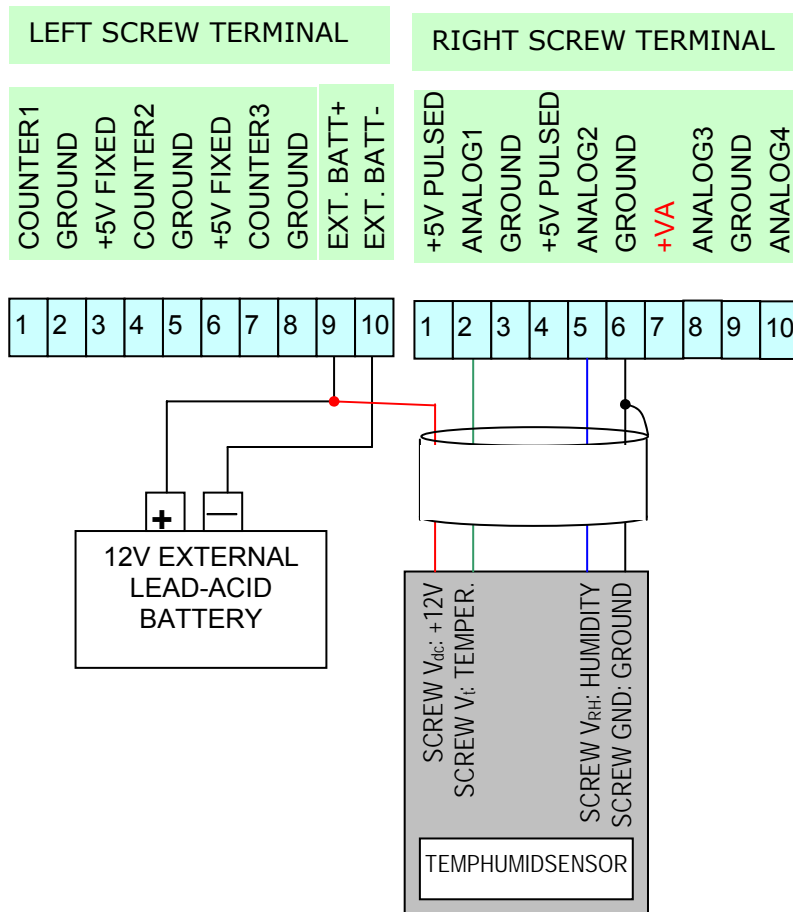

#### **IN CASE IT DOESN'T WORK:**

- Connect the sensor to the battery.
- With a multimeter check the voltage between TEMPERATURE and GROUND: At ambient temperature 20 °C it should be about 0.5V.
- With a multimeter check the voltage between HUMIDITY and GROUND: At an ambient humidity 70% it should be about 0.7V.

## SETUP:

Before changing the logger's setup select:  
**5> ACQ OFF** (press [5] and [ENTER]).

After changing setup select:  
**5>ACQ ON** (press [5] and [ENTER])

to start acquisition (data logging).

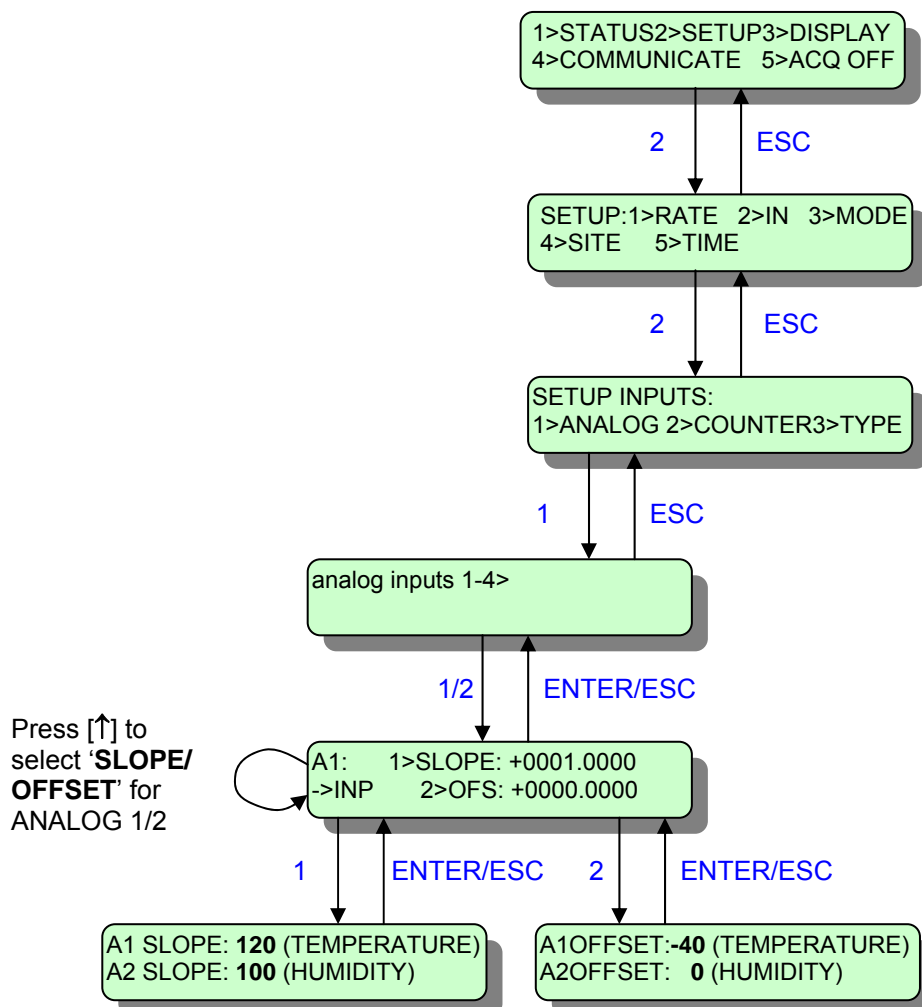

Coefficients for display in:  
 TEMPERATURE: -40 ~ +80 °C  
 HUMIDITY: 0 ~ 100 %

## 15. TEMPERATURE-HUMIDITY Ammonit P6312

- Connect the first sensor to screws 2 [ANALOG1], 5 [ANALOG2] and 3 [GROUND] on the right screw terminal.
- Connect the second sensor to screws 8 [ANALOG3], 10 [ANALOG4] και 9 [GROUND] on the right screw terminal.
- Wire polarity does matter (see drawing): The sensor connects to an external +7V ~ +30VDC power source (typically a 12V lead-acid battery). The sensor GROUND together with the cable shield connects to a logger GROUND position. Typical wire size: 4 x 0,25 mm<sup>2</sup> (shielded cables are recommended).

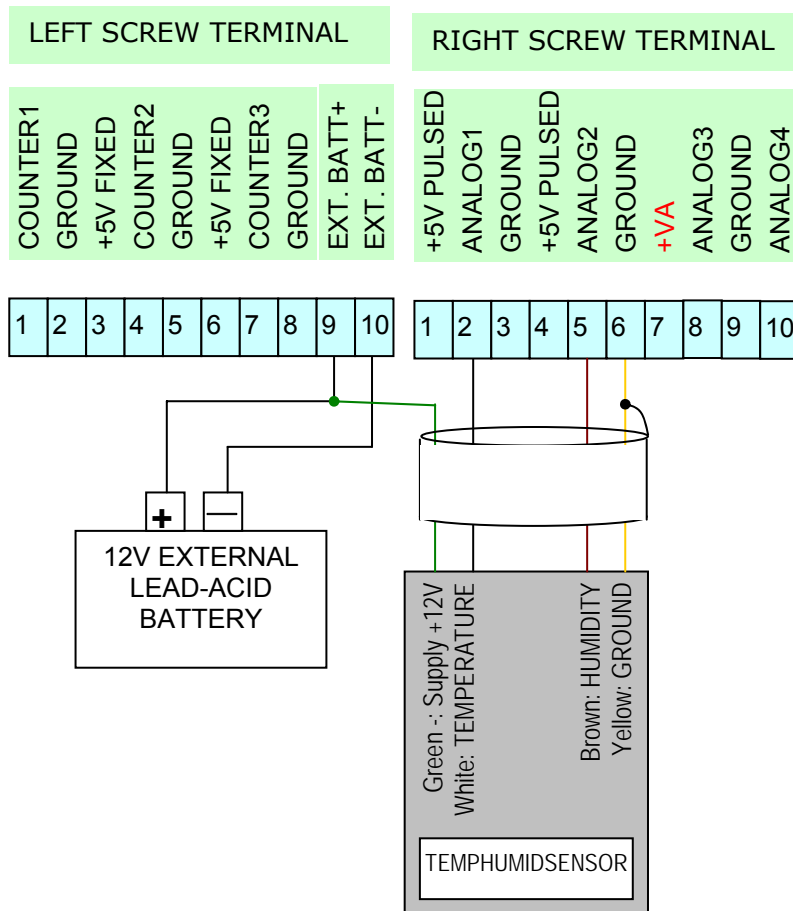

### **IN CASE IT DOESN'T WORK:**

- Connect the sensor to the battery.
- With a multimeter check the voltage between TEMPERATURE and GROUND: At ambient temperature 20 °C it should be about 0.5V.
- With a multimeter check the voltage between HUMIDITY and GROUND: At an ambient humidity 70% it should be about 0.7V.

## SETUP:

Before changing the logger's setup select:  
**5> ACQ OFF** (press [5] and [ENTER]).

After changing setup select:  
**5>ACQ ON** (press [5] and [ENTER])  
 to start acquisition (data logging).

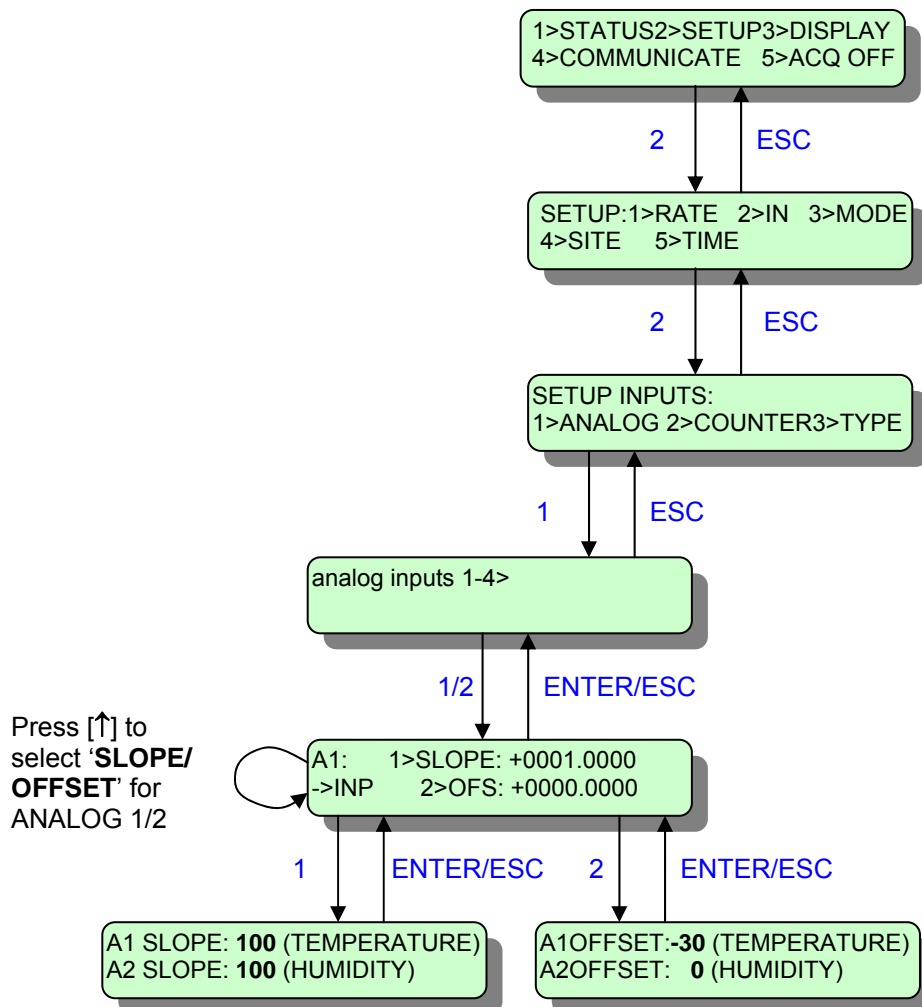

Coefficients for display in:  
 TEMPERATURE: -30 ~ +70 °C  
 HUMIDITY: 0 ~ 100 %

## 16. TEMPERATURE-HUMIDITY Vaisala HMP50

- Connect the first sensor to screws 2 [ANALOG1], 5 [ANALOG2] and 3 [GROUND] on the right screw terminal.
- Connect the second sensor to screws 8 [ANALOG3], 10 [ANALOG4] και 9 [GROUND] on the right screw terminal.
- Wire polarity does matter (see drawing): The sensor connects to an external +7V ~ +30VDC power source (typically a 12V lead-acid battery). The sensor GROUND together with the cable shield connects to a logger GROUND position. Typical wire size: 4 x 0,25 mm<sup>2</sup> (shielded cables are recommended).

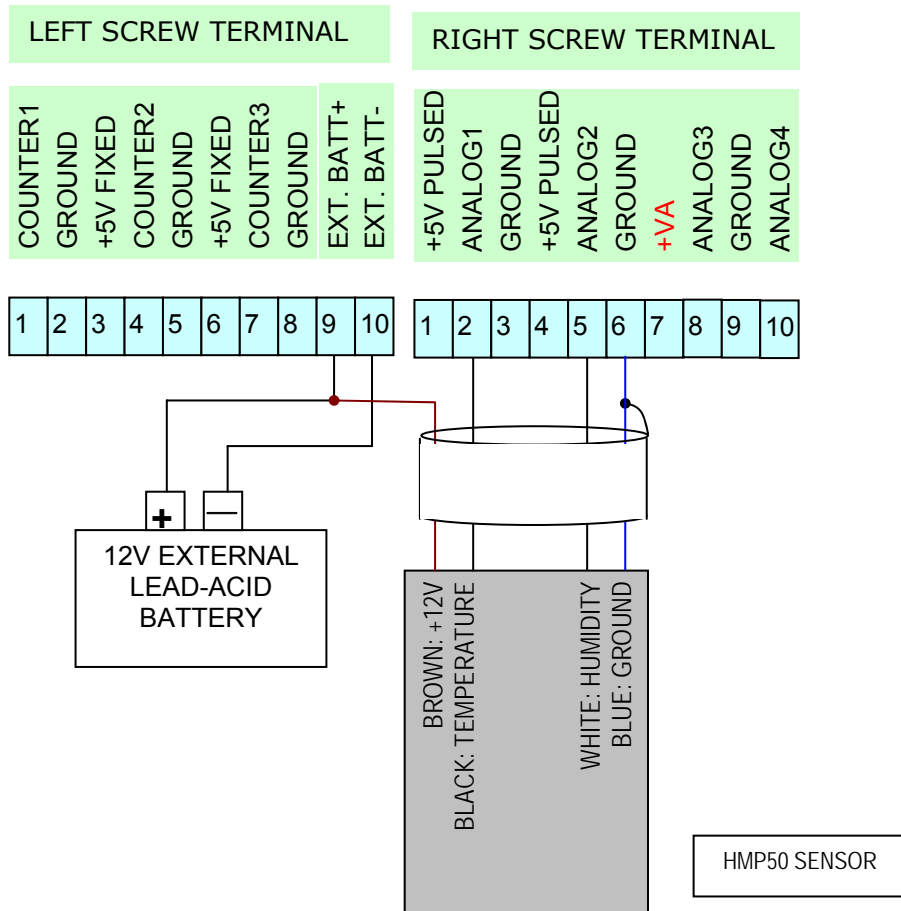

### **IN CASE IT DOESN'T WORK:**

- Connect the sensor to the battery.
- With a multimeter check the voltage between TEMPERATURE and GROUND: At ambient temperature 20 °C it should be about 0.5V.
- With a multimeter check the voltage between HUMIDITY and GROUND: At an ambient humidity 70% it should be about 0.7V.

## SETUP:

Before changing the logger's setup select:  
**5 > ACQ OFF** (press [5] and [ENTER]).

After changing setup select:  
**5 > ACQ ON** (press [5] and [ENTER])  
 to start acquisition (data logging).

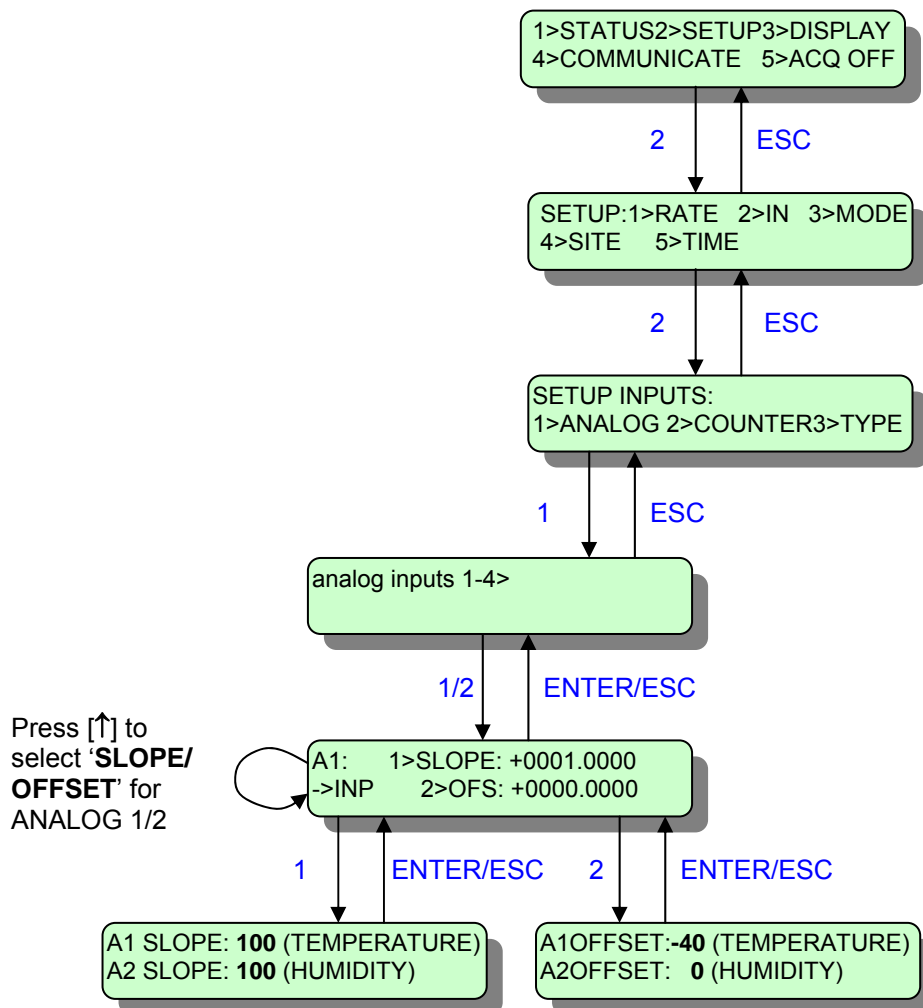

Coefficients for:  
 TEMPERATURE: -40 ~ +60 °C  
 HUMIDITY: 0 ~ 100 %

| HMP50 output | SLOPE (TEMP) | OFFSET (TEMP) | SLOPE (HUMID) | OFFSET (HUMID) |
|--------------|--------------|---------------|---------------|----------------|
| 1V           | 100.0000     | - 40.0000     | 100.0000      | 0.0000         |
| 2.5V         | 40.0000      | - 40.0000     | 40.0000       | 0.0000         |
| 5V           | 20.0000      | - 40.0000     | 20.0000       | 0.0000         |

## 17. PYRANOMETER LiCor LI-200SA

### CONNECTION:

- Remove the data logger's front panel and make sure that the following resistors are in place (set A3 input gain)<sup>(1)</sup>:
  - Resistor R65=115K, 0.1%
  - Resistor R66=1K, 0.1%
- Connect a 147-Ohm, 0.1% resistor to terminals 8 [ANALOG3] and 9 [GROUND] in the right-hand terminal block, i.e. terminate A3 for correct current-to-voltage conversion.
- Connect the sensor to terminals 8 [ANALOG3] and 9 [GROUND] in the right-hand terminal block.
- Wire polarity does matter (see drawing): The **red** wire of the sensor connects to screw 9 [GROUND]. The black wire together with the shield is connected to [ANALOG3].
- Typical wire size: 2 x 0,25 mm<sup>2</sup> (shielded cables are recommended).
- Slope and offset calculation.  
If  $P_{uA}$  is the sensor's sensitivity in  $\mu\text{A}/1000\text{W}/\text{m}^2$  and R65, R66 are in kOhms, then:

$$\text{Slope} = \frac{R66 \cdot 10^9}{P_{uA} \cdot 147 \cdot (R65 + R66)} \quad [\text{W}/\text{m}^2]$$

With a typical  $P_{uA} = 80\mu\text{A}$ , we have  $\text{Slope} = 733,052$

$\text{Offset} = 0$

<sup>(1)</sup> Note: You can use other resistor values in the range of 1 to 500 kOhm

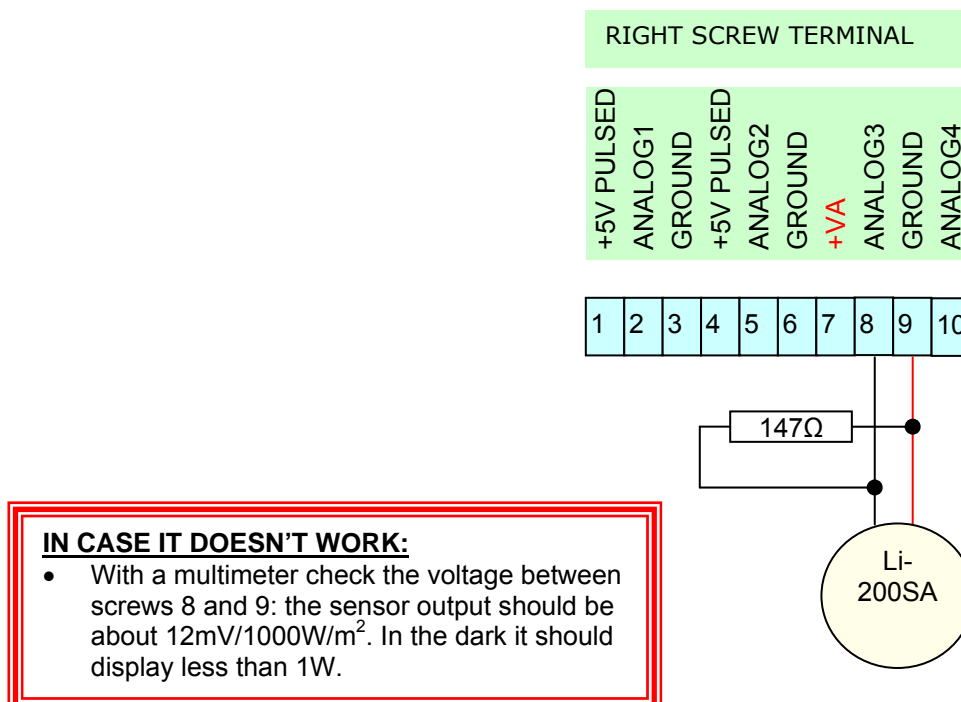

## SETUP:

Before changing the logger's setup select:  
**5> ACQ OFF** (press [5] and [ENTER]).

After changing setup select:  
**5>ACQ ON** (press [5] and [ENTER])  
 to start acquisition (data logging).

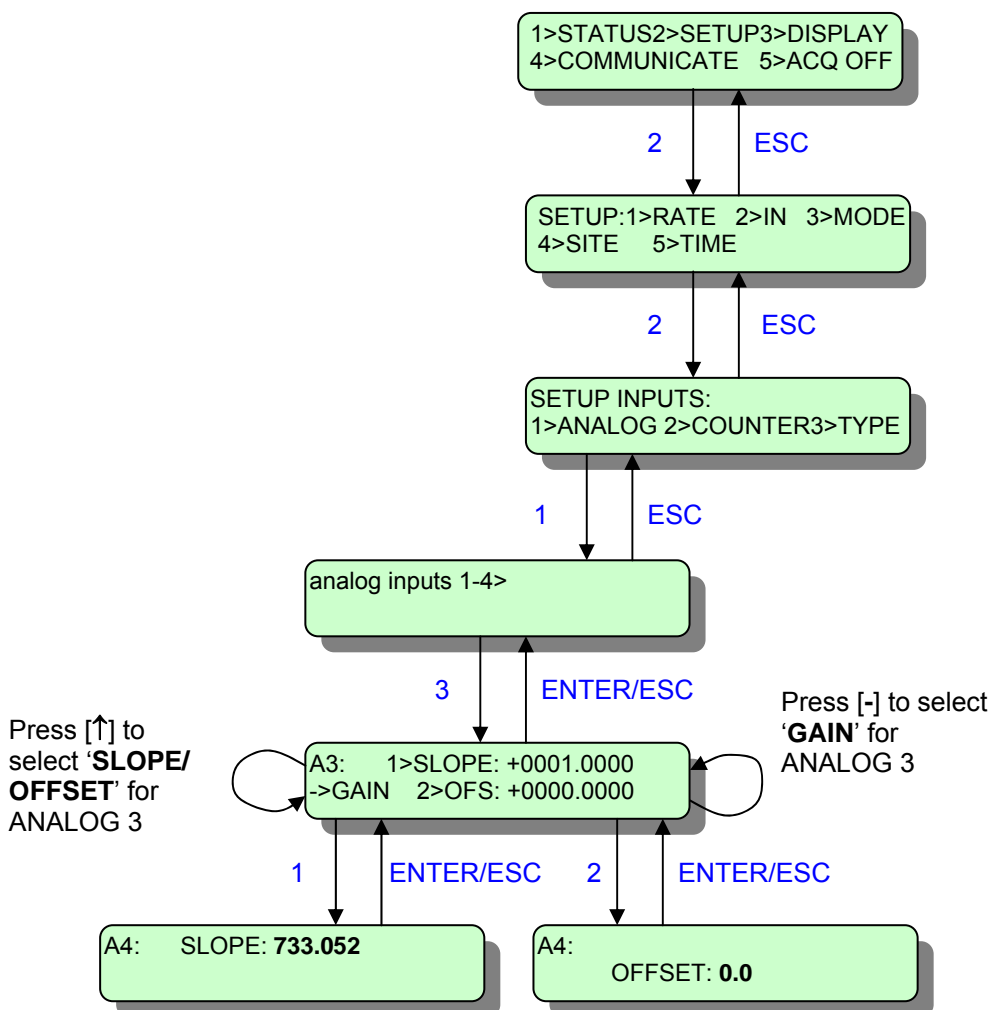

Coefficients shown are for indication in  $W/m^2$  with a typical sensitivity of  $80\mu A/1000W/m^2$ . If the pyranometer is calibrated calculate the coefficients as shown above.

## 18. PYRANOMETER SKYE SKS-1110

### CONNECTION:

- Remove the data logger's front panel and make sure that the following resistors are in place (set A3 input gain):
  - Resistor R65=115K, 0.1%
  - Resistor R66=1K, 0.1%
- Connect the sensor to terminals 8 [ANALOG3] and 9 [GROUND] in the right-hand terminal block.
- Remove the connector (if any) from the wire end. Wire polarity does matter (see drawing): The **red** wire together with the **blue** wire of the sensor connect to [GROUND]. The shield is connected to [ANALOG].
- Typical wire size: 2 x 0,25 mm<sup>2</sup> (shielded cables are recommended).

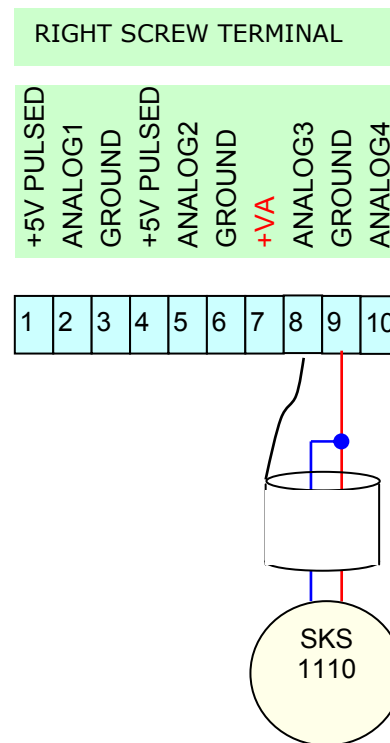

#### **IN CASE IT DOESN'T WORK:**

- With a multimeter check the voltage between screws 8 and 9: the sensor output should be about 100mV/1000W/m<sup>2</sup>. In the dark it should display less than 1W.

## SETUP:

Before changing the logger's setup select:

**5> ACQ OFF** (press [5] and [ENTER]).

After changing setup select:

**5> ACQ ON** (press [5] and [ENTER])

to start acquisition (data logging).

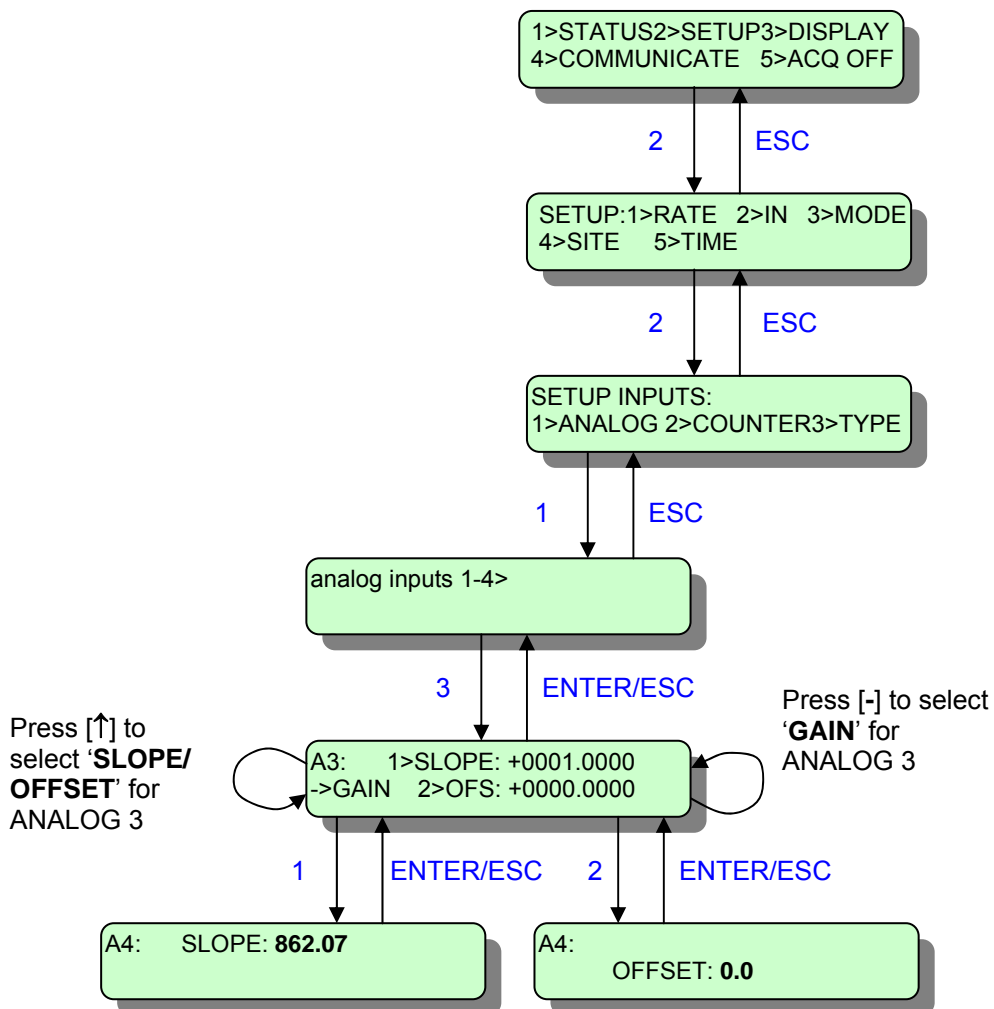

Coefficients shown are for indication in  $W/m^2$

## 19. 4 ~ 20mA TRANSMITTERS

SDP-5 depth sensor, etc. with a setup time of 2msec or less<sup>(1)</sup>.

### CONNECTION:

- Connect the first sensor to screws [+VA PULSED] and 10 [ANALOG4] on the right screw terminal.
- Connect the second sensor to screws 7 [+VA PULSED] and 8 [ANALOG3] on the right screw terminal.
- Wire polarity does matter (see drawing): The red wire of the sensor connects to screw 7 [+VA PULSED]. The black wire of the sensor connects to positions [ANALOG4 or 3] only.
- Consult the Stylitis User's Manual to make sure that position 7 [+VA PULSED] generates +12V or +18V and not +5V. Also make sure that inputs [ANALOG4] or [ANALOG3] have resistors R8 (20Ω, 0.1%) or R7(20Ω, 0.1%) in place.

(1) **Important Notice:** Stylitis firmware allows 2 milliseconds for the sensor to power up. If you sensor requires a longer setup time then connect the red wire directly to the 12V battery (in this case you can use a Stylitis-41 as well). If in doubt contact Symmetron.

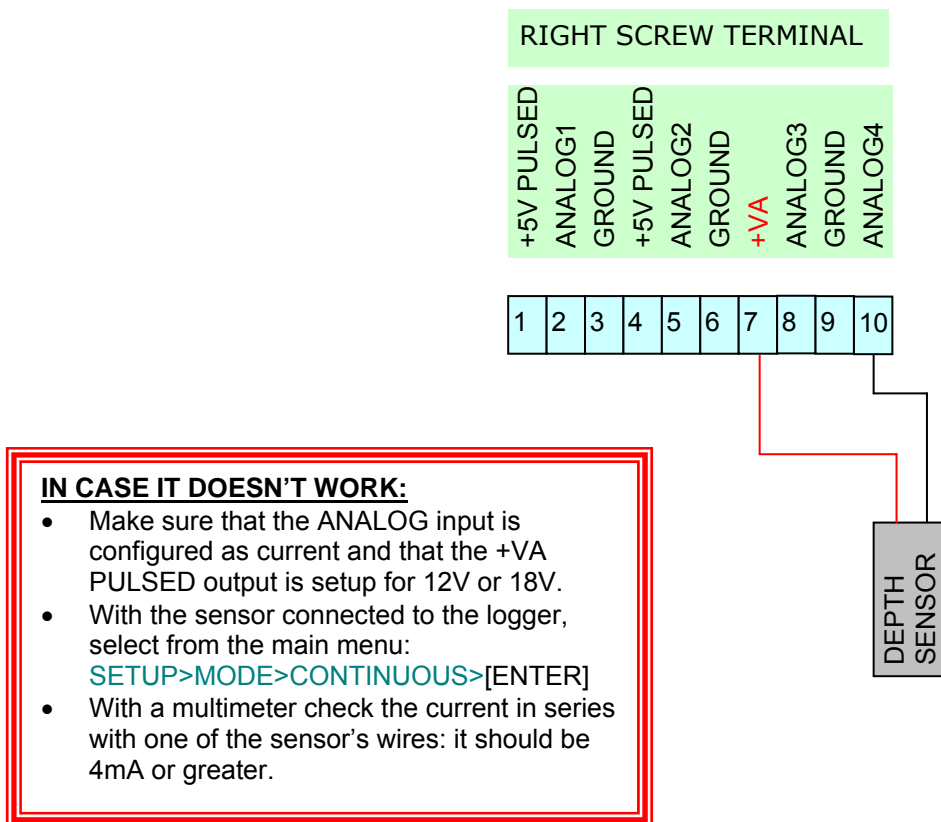

## SETUP:

Before changing the logger's setup select:  
**5> ACQ OFF** (press [5] and [ENTER]).

After changing setup select:  
**5>ACQ ON** (press [5] and [ENTER])  
 to start acquisition (data logging).

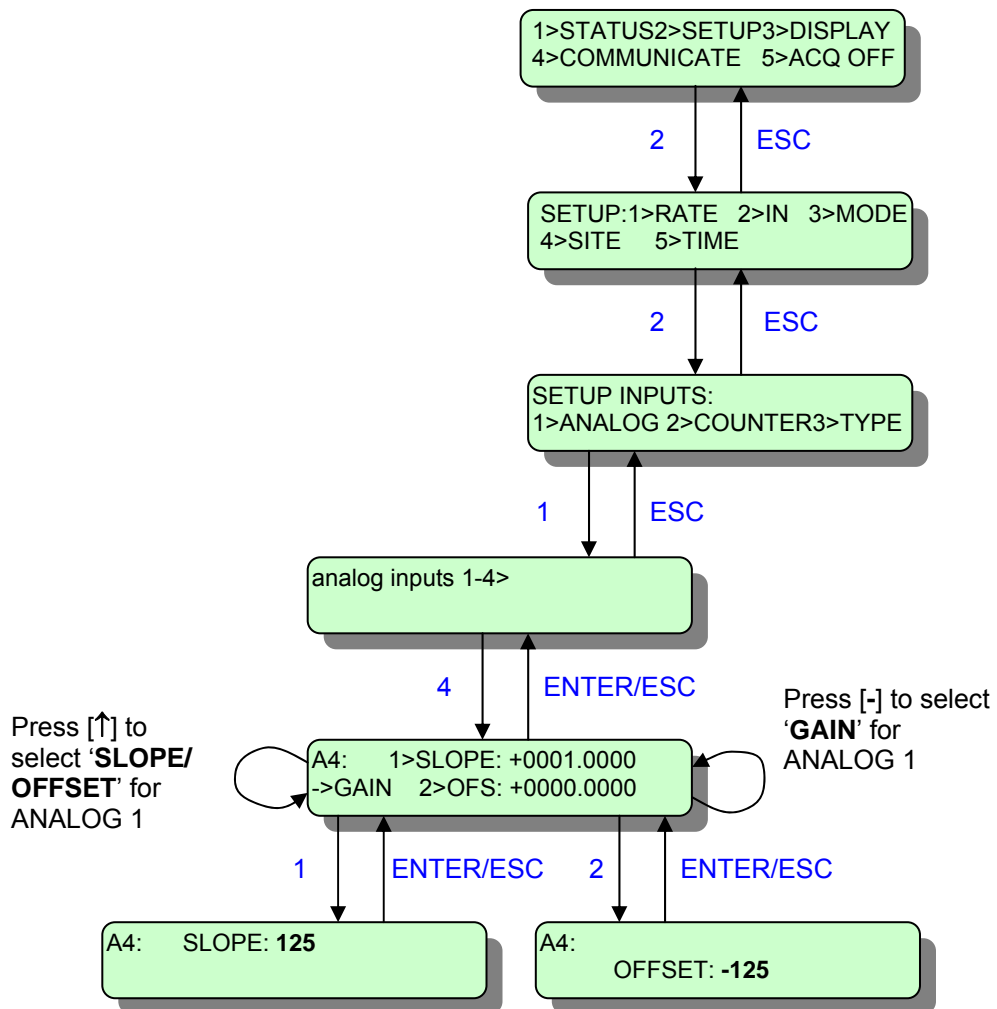

Coefficients for conversion to centimeters.  
 For calibrated sensors enter the correct  
 SLOPE and OFFSET values.

## 20. SYMMETRON TILTOMETER

### CONNECTION:

- Connect the first sensor to screws 2 [ANALOG1], 5 [ANALOG2] and 3 [GROUND] on the right screw terminal.
- Connect the second sensor to screws 8 [ANALOG3], 10 [ANALOG4] και 9 [GROUND] on the right screw terminal.
- If you have only one input free, connect just the Elevation.
- Wire polarity does matter (see drawing): The Tiltometer connects to an external +6V ~ +15VDC power source (typically a 12V lead-acid battery). The sensor GROUND together with the cable shield connects to a logger GROUND position. Typical wire size: 4 x 0,25 mm<sup>2</sup> (shielded cables are recommended).

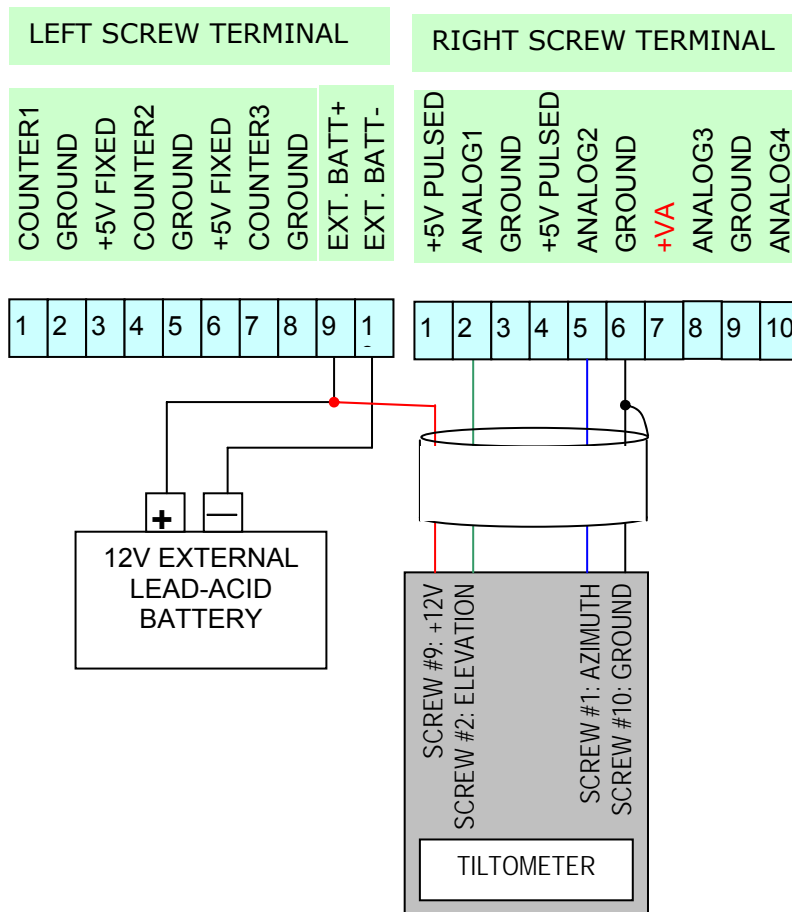

#### **IN CASE IT DOESN'T WORK:**

- Connect the sensor to the battery.
- With a multimeter check the voltage between ELEVATION and GROUND: When the Tiltometer is placed flat horizontally it should be about 2.5V.
- With a multimeter check the voltage between AZIMUTH and GROUND: When the Tiltometer is placed horizontally and is rotated around its longest axis it should vary from 0 to 5V.

## SETUP:

Before changing the logger's setup select:  
**5> ACQ OFF** (press [5] and [ENTER]).

After changing setup select:  
**5>ACQ ON** (press [5] and [ENTER])

to start acquisition (data logging).

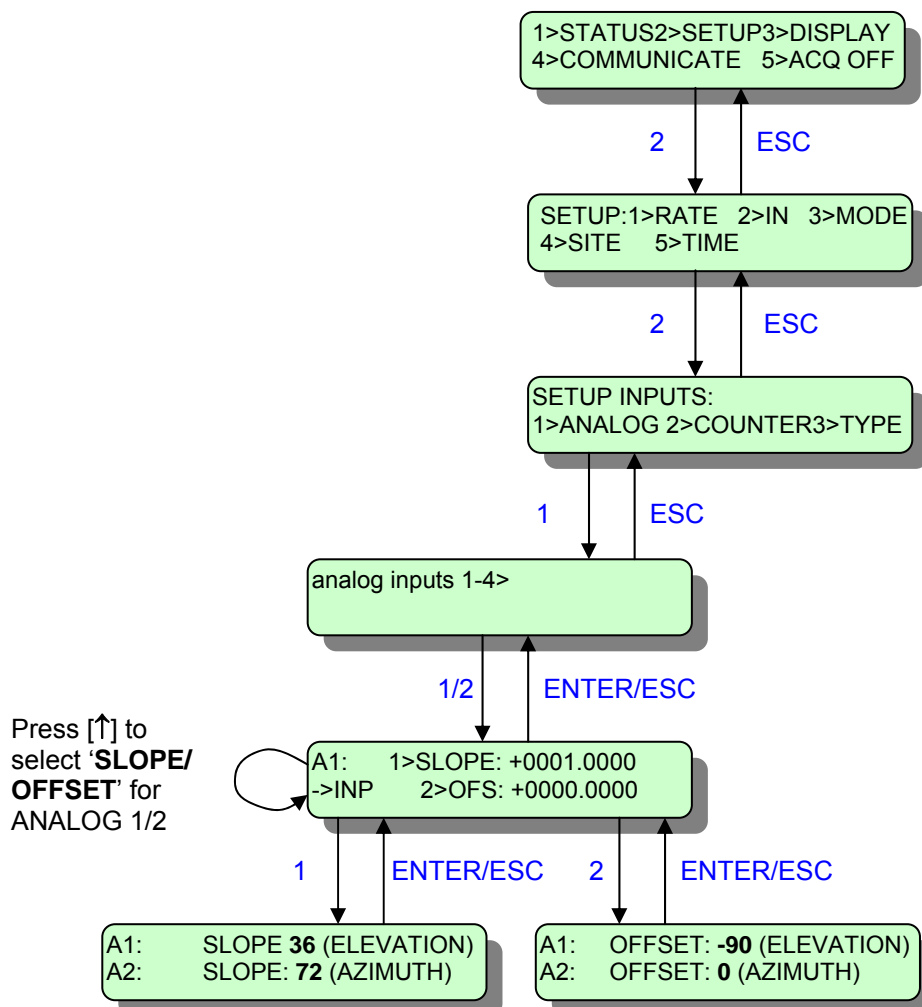

Coefficients for display in degrees:  
 ELEVATION: +90 ~ -90  
 AZIMUTH: 0 ~ 360

## 21. FLOW METERS.

Open-collector sensors: DIGMESA Flowmeters

### CONNECTION:

- Connect the first flow meter to screws 1 [COUNTER1] and 2 [GROUND] on the left screw terminal.
- Connect the second flow meter to screws 4 [COUNTER2] and 5 [GROUND] on the left screw terminal.
- Connect the third flow meter to screws 7 [COUNTER3] and 8 [GROUND] on the left screw terminal.
- Wire polarity does matter (see drawing). Typical wire size: 3 x 0,25 mm<sup>2</sup> (shielded cables are recommended). Connect the shield to the GROUND screw.

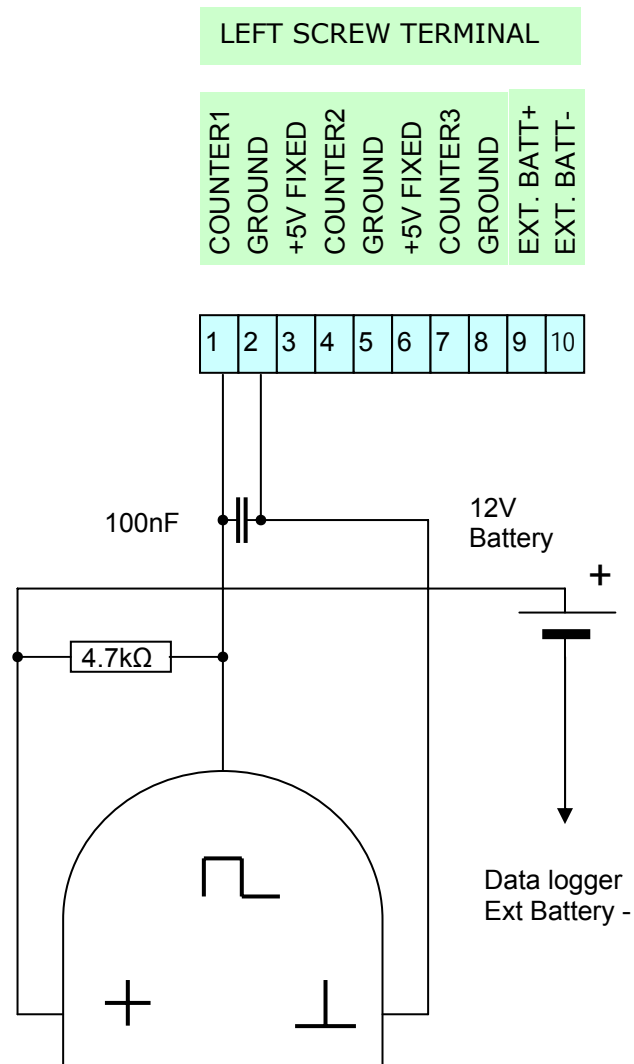

## SETUP:

Before changing the logger's setup select:  
**5> ACQ OFF** (press [5] and [ENTER]).

After changing setup select:  
**5>ACQ ON** (press [5] and [ENTER])

to start acquisition (data logging).

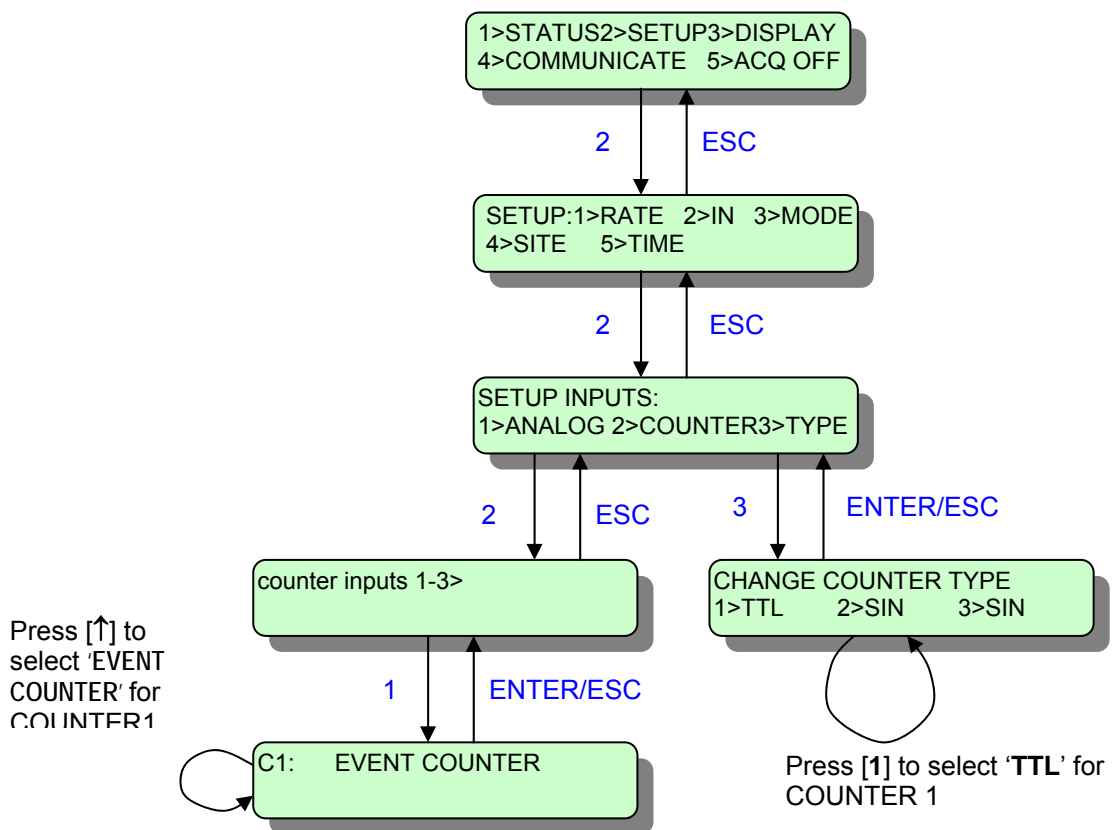

NOTE: You can set appropriate Slope and Offset coefficients for Event counters in Stylitis Explorer | Site Properties.

## 22. SYMMETRON TIMER FOR TC35T GSM MODEM

Switches ON and OFF the modem according to a daily program. Conserves battery power and resets the modem.

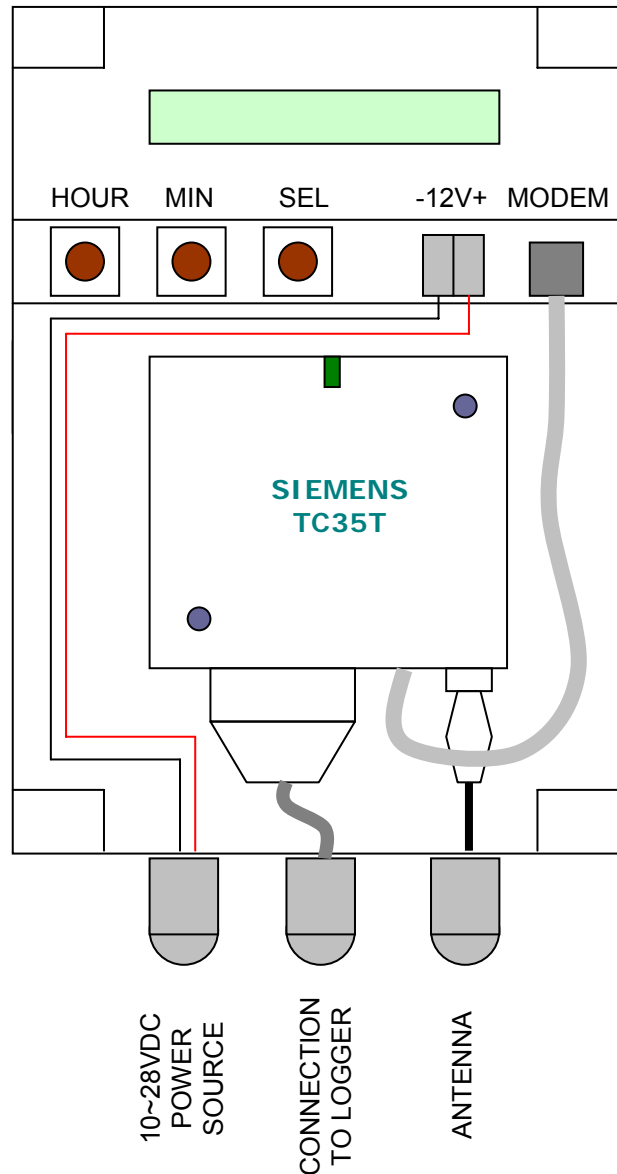

### TIMER SETUP

1. Includes a back-up cell to keep setup and time for at least 3 years. Without an external power supply the modem and the display are always off. Protected from reverse supply connection. Power supply: 10~ 28VDC, 2mA. Enclosure: IP65, 20x12x7cm (includes modem). Operation temperature: -30 ~ +70°C.

2. Place the modem in the box and connect it as shown in the diagram. Connect power; the display should come up. Use the *SEL* button to select:

**Auto.** The default display. Shows current time. ON is displayed when on.

**SetClok.** Use the *HOUR*, *MIN* buttons to set current time.

**SetON.** Use the *HOUR*, *MIN* buttons to set the ON time.

**SetOFF.** Use the *HOUR*, *MIN* buttons to set the OFF time.

**AlwaysON.** The timer is continuously ON.

**AlwaysOFF.** The timer is continuously OFF.

3. The timer program works when **Auto**, **SetClok**, **SetON** or **SetOFF** is displayed. 41

## 23. BATTERY, SOLAR CELL AND TIMER CONNECTION TC35T:

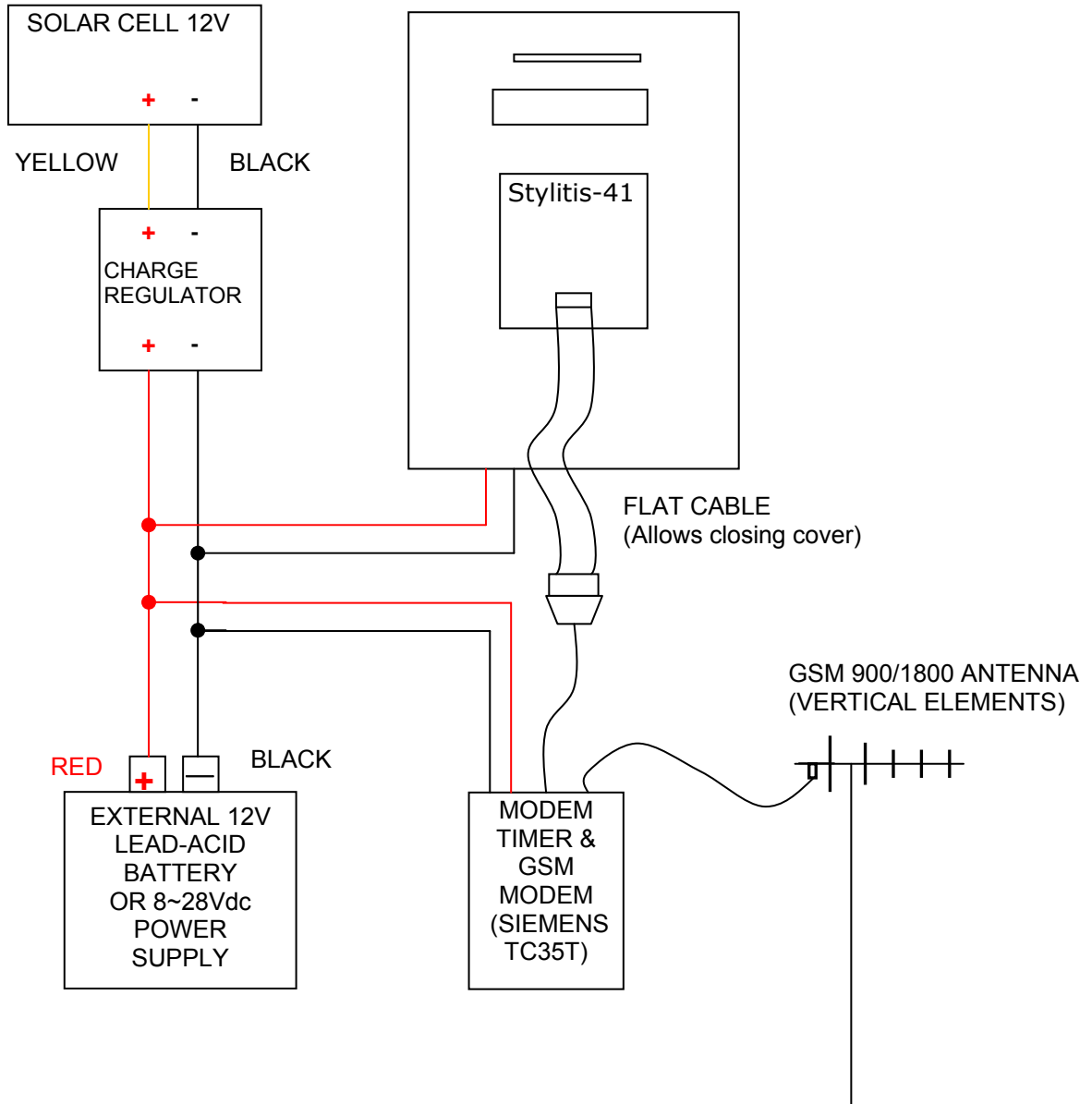

### TC35T MODEM SETUP

1. **Disconnect the modem from the power supply.**
2. Press the yellow button on modem's side, take out the drawer and place the SIM card. (You can un-lock the SIM card (using a standard cellular phone) to avoid re-entering the PIN number each time the modem power supply is removed). Push the drawer back in place.
3. Connect the power supply to the modem. The green light should start blinking rapidly. Enter the PIN code (see above).
4. Wait a few seconds; the green light should start blinking slowly.
5. Go to the COMMUNICATE>MODEM menu: the network operator's name and the signal strength (SIGNAL) should appear in the display. BER shows errors (0 or 99 is OK).
6. In case you are using a directional antenna, turn it around to maximize the "SIGNAL". A value of at least "14" is recommended.

## CONNECTION M20T:

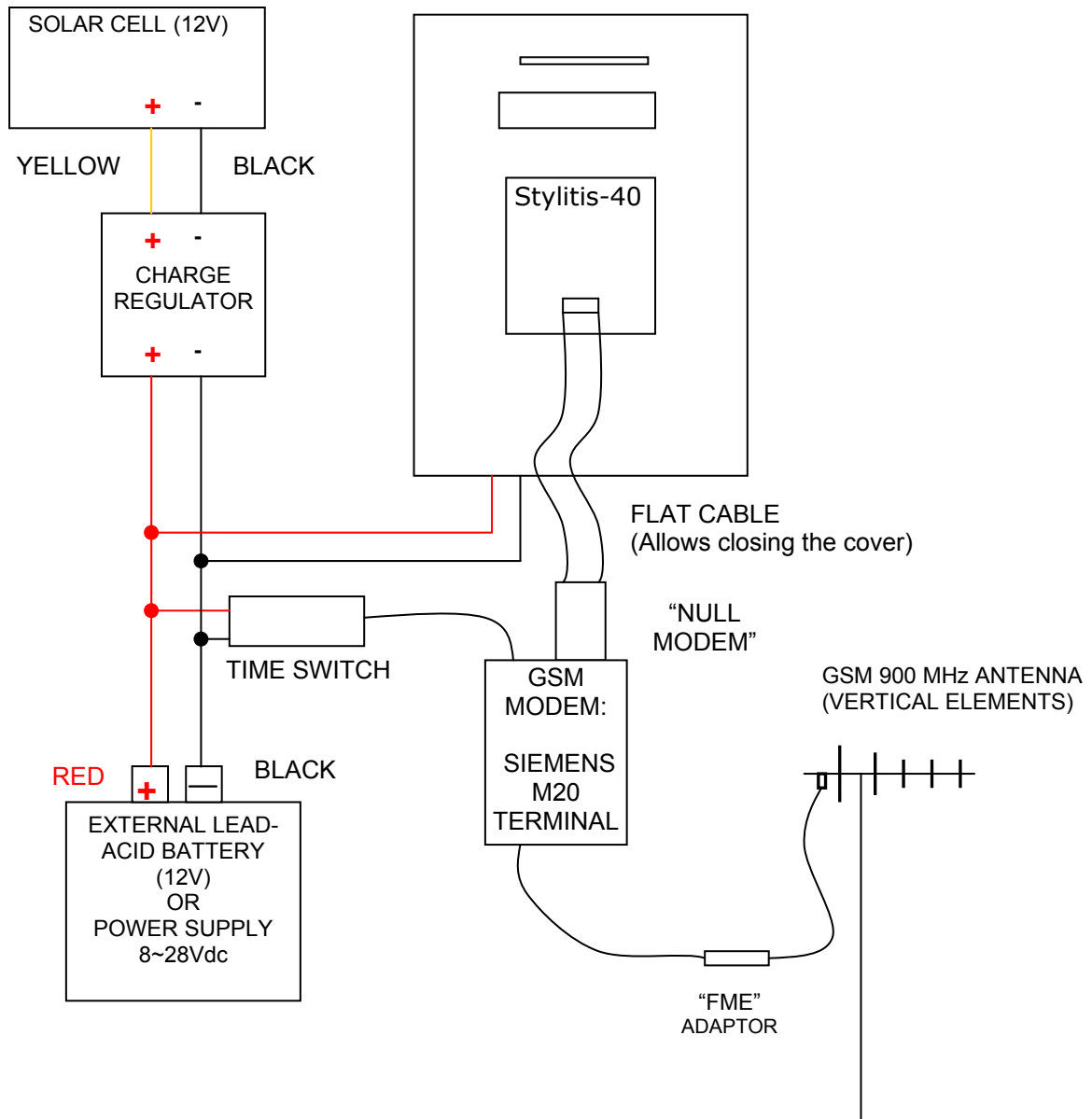

### **M20T MODEM SETUP**

1. Disconnect the modem from the power supply.
2. Press the yellow button on modem's side, take out the drawer and place the SIM card. Push the drawer back in place.
3. Connect the power supply to the modem. The green light should start blinking.
4. Enter the PIN code (see above).
5. Go to the "Modem" menu (see above). Wait a few seconds; the green light should stop blinking and the network operator's name should appear in the display.
6. In case you are using a directional antenna, turn it around to maximize the "SIGNAL". A value of at least "14" is recommended.
7. You can un-lock the SIM card (using a standard cellular phone) to avoid re-entering the PIN number each time the modem power supply is removed.

## CONNECTION 1206/1306:

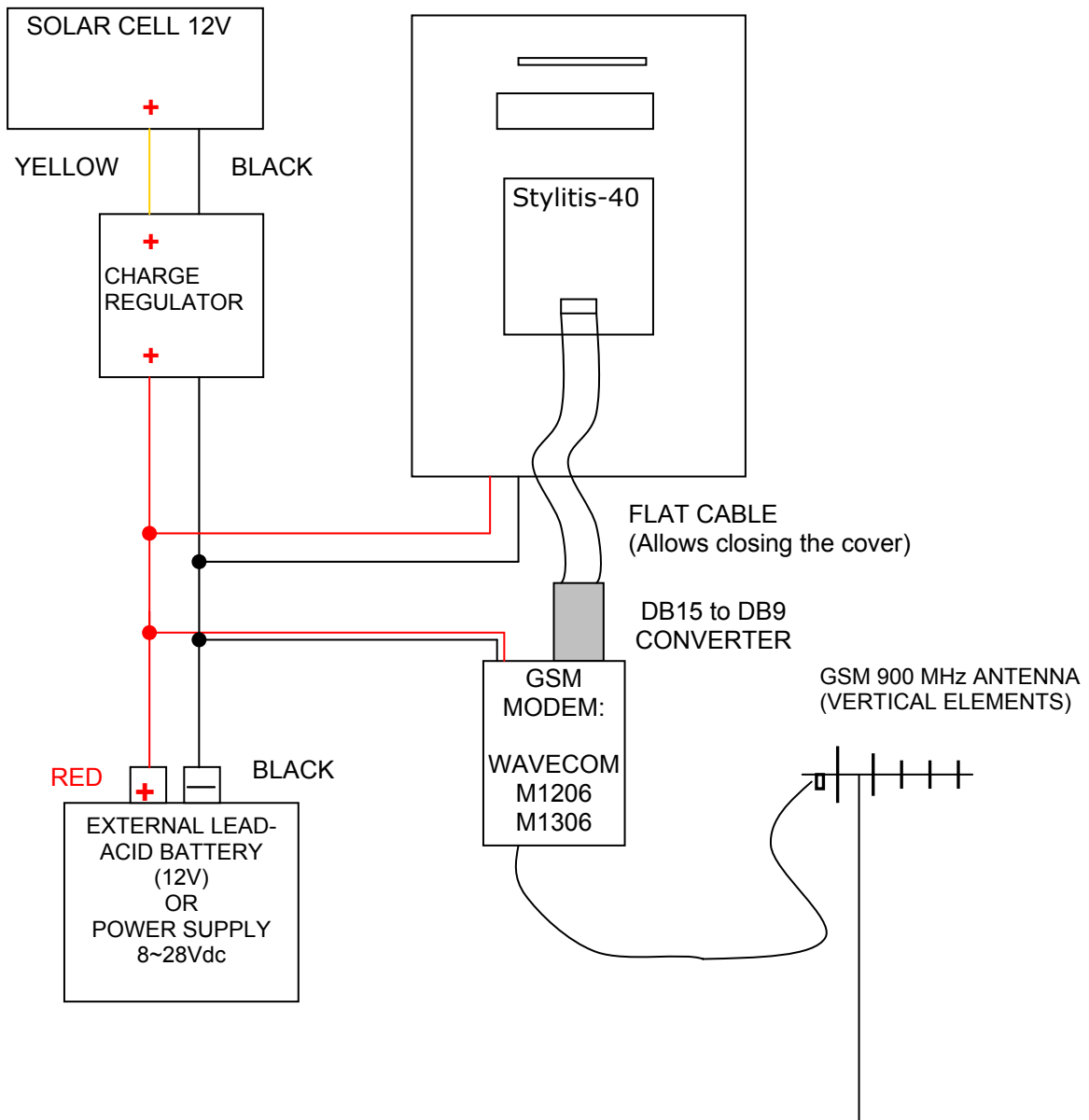

### **WAVECOM M1206/1306 MODEM SETUP**

1. Disconnect the modem from the power supply.
2. Press the black button on modem's side, take out the drawer and place the SIM card. Push the drawer back in place.
3. Connect the power supply to the modem. The red light should light up.
4. Enter the PIN code (see above).
5. Wait a few seconds; the red light should start blinking **slowly**.
6. Go to the COMMUNICATE>MODEM menu: the network operator's name and the signal strength (SIGNAL) should appear in the display. BER shows errors (0 or 99 is OK).
7. In case you are using a directional antenna, turn it around to maximize the "SIGNAL". A value of at least "14" is recommended.

## SOLAR PANEL CONNECTION:

If more than one solar panel are connected to a system it is recommended that each one is connected to the Charge Regulator via a diode:

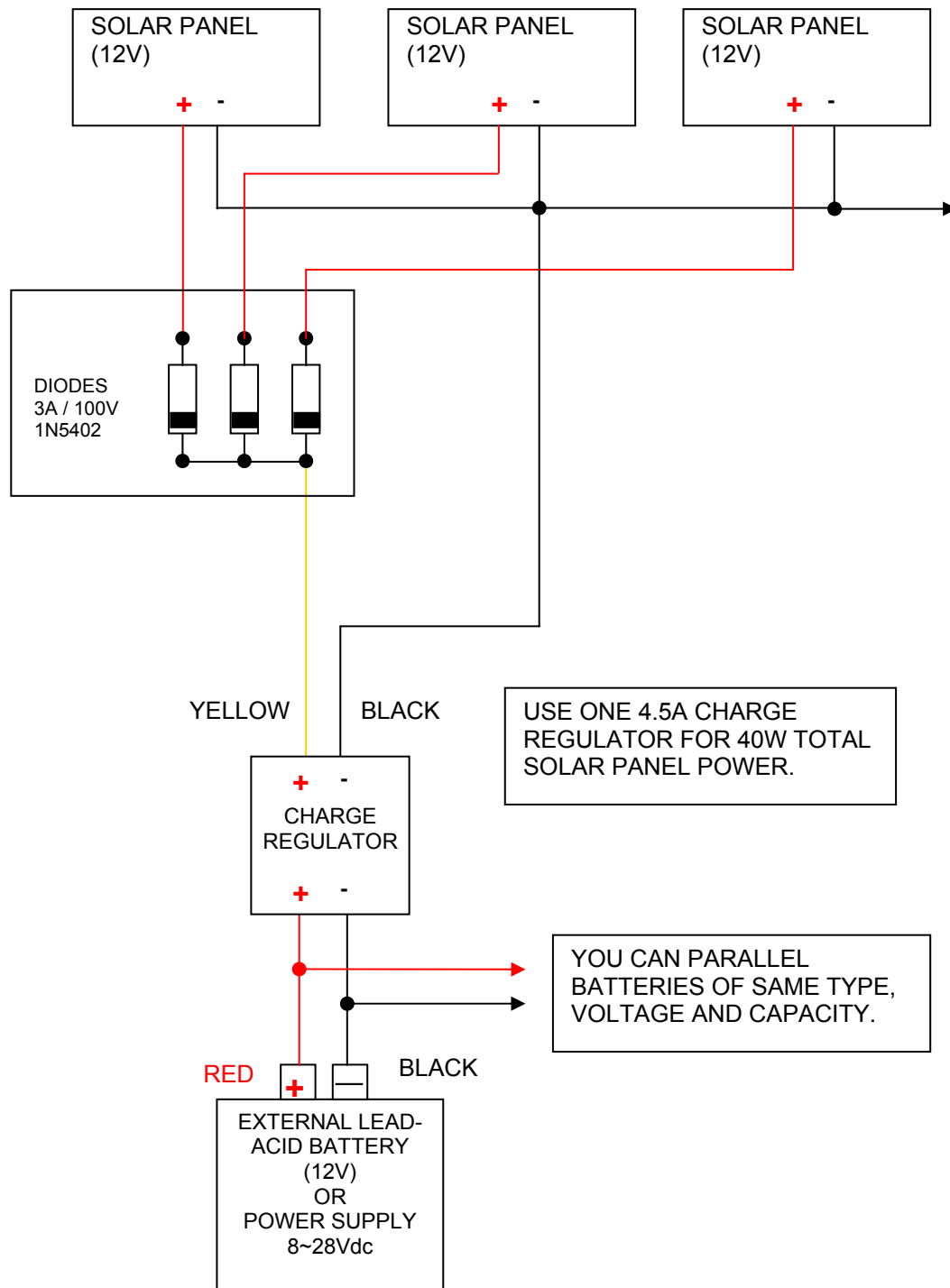

## 24. DATA LOGGER MESSAGES

FULL CARD - REMOVE

Full memory card. Replace with an empty one (latest firmware allows card erasure in-site). Data are stored in buffer.

CARD ERROR - REMOVE

Card is bad. Replace.

LOW CARD BATTERY- REMOVE

ONLY FOR SRAM CARDS: Card is not acceptable. Card's battery needs replacement.

PRESS <ESC> TO LEAVE  
<ENTER> TO CLEAR CARD

Press [ENTER] to erase card contents. Press ESC] to quit.

NOT ERASED [1>CLEAR]  
[- REMOVE]

Flash Card is not acceptable because it has been used in a different logger. Depending on version: press 1 to erase or use an erased card.

INVALID CARD - REMOVE

Card is not acceptable because the logger does not recognize it. Use another card.

BUFFER FULL

Logger's buffer is full and data logging has stopped.

LOW BATTERY -CANNOT  
START ACQUISITION

Acquisition cannot be started because battery voltage is less than 5.75V.

ACQ ON  
Data in card

Data are stored in memory card.

ACQ ON Data in Buffer  
Card full

Memory card is full and data are stored in the internal memory (buffer).

ACQ ON Buffer full  
Card full

Acquisition stops when the memory card and the internal buffer are full. Replace with an erased card to retrieve buffer data.

ACQ ON Data in Buffer  
No Card

Data are stored in buffer. There is no memory card.

ACQ ON Buffer full  
No Card

Acquisition stops when internal buffer is full. There is no memory card.

STOP ACQUISITION  
& CLEAR BUFFER DATA?

WHEN CHOOSING ACQUISITION OFF:

- Internal buffer data are cleared.
- The open card file is closed.
- Data recording stops.

START ACQUISITION?

WHEN CHOOSING ACQUISITION ON:

- A new file is opened on the memory card.
- Data recording starts.

## 25. LOGGER QUICK CHECK

The checks described below are not a substitute for a standard lab check. However they can be exercised to gain 'correct operation' confidence with a probability high enough.

*NOTE: Measured values depend on the accuracy of the multimeter used.*

### 1. ANALOG OUTPUT CHECK

- From the main menu select: **SETUP>MODE>CONTINUOUS>**[ENTER]
- With a multimeter measure the +5V PULSED outputs on the right screw terminal.
- Correct measured value is +5V.
- With a multimeter measure the +VA PULSED output on the right screw terminal.
- Correct measured value is +5V (or +12V or +18V for Stylitis-42).

### 2. ANALOG INPUT CHECK

- From the main menu select: **SETUP>IN>ANALOG** and set all inputs (A1~A4) to SLOPE=1.0 and OFFSET=0.0
- Connect a +5V PULSED output to the analog input you want to test.
- From the main menu select: **DISPL>ANALOG**
- Correct value is 5V.
- For Stylitis-42, the 0~20mA current inputs (A4 and A3) must have the GAIN option enabled (see: 8. DEPTH SENSOR SDP-5).

### 3. FIXED OUTPUT CHECK

- With a multimeter measure the +5V FIXED output on the left screw terminal.
- Correct measured value is about +5V.

### 4. COUNTER INPUT CHECK

- From the main menu select: **SETUP>IN>COUNTER** and set all inputs (C1~C3) with SLOPE=1.0 and OFFSET=0.0
- From the main menu select: **SETUP>IN>TYPE** and set all inputs for 'TTL'.
- From the main menu select: **SETUP>MODE>ENERGY SAVE>**[ENTER]
- Connect a +5V PULSED output to the counter input you want to test.
- From the main menu select: **DISPL>COUNTER**
- Correct measured value is '1.0'.

## 26. CONNECTION EXAMPLE

