

# TILTOMETER V1.0

## USER'S MANUAL



Copyright ©2007, the Symmetron Company.

Fourth Edition in English, June 2007.

No part of this publication may be reproduced, stored in a retrieval system, or transmitted, in any form by any means, without the prior written permission of Symmetron Company.

Information furnished by Symmetron is believed to be accurate and reliable; however, no responsibility is assumed for its use. No license is granted by implication or otherwise.

Symmetron® is a registered trademark. Stylitis™ and Tiltometer™ are trademarks of the Symmetron Company.

All other trademarks belong to their respective owners.

## WARRANTY

The Symmetron Company warrants its products shall be free from defects on materials and workmanship under normal use for the period of 1 year. Symmetron's obligation under this warranty shall not arise until buyer returns the defective product, freight prepaid to Symmetron's facility or another specified location.

The only responsibility of Symmetron under this warranty is, at its option, to replace or repair, free of charge, any defective component of such products.

THE WARRANTY DOES NOT EXTEND TO AND SHALL NOT APPLY TO:

1. Products which have been repaired or altered by other than Symmetron's personnel, unless Buyer has properly altered or repaired the products in accordance with procedures previously approved in writing by Symmetron.
2. Products, which have been subject to misuse, neglect, accident, improper installation, or direct lightning strikes.

THE WARRANTY AND REMEDIES SET FORTH ABOVE ARE IN LIEU OF ALL OTHER WARRANTIES EXPRESSED OR IMPLIED, ORAL OR WRITTEN, EITHER IN FACT OR BY OPERATION OF LAW.

THE SYMMETRON COMPANY SHALL HAVE NO LIABILITY FOR INCIDENTAL OR CONSEQUENTIAL DAMAGES OF ANY KIND ARISING OUT OF THE SALE, INSTALLATION, OR USE OF ITS PRODUCTS.

---

RETURN OUTSIDE GREECE

Contact Symmetron for authorization and shipping instructions.

---

SYMMETRON ELECTRONIC APPLICATIONS

TEL: +30-210-603-4002, FAX: +30-210-603-4003

e-mail: [symmet@symmetron.gr](mailto:symmet@symmetron.gr)

Internet: <http://www.symmetron.gr/>

Made in Greece.



N. Hadzidakis – T. Katsabakou Co.  
54, Leontariou St. 15351 Pallini,  
Greece

## MANUFACTURER'S DECLARATION OF CONFORMITY

I, the undersigned, hereby declare that the equipment specified conforms to the below Directives and Standards.

### Standards to which Conformity is Declared

EMC Emissions: EN61326:1998  
EMC Immunity: EN61326:1998  
Protection: EN60529:1992

### Description of Equipment

Angle sensor.

### Model

Tiltometer

### Batch of product covered

Serial numbers: from 0 to 2000

### Date and Place

Pallini, Attica, Greece, December 1, 2006.

### Authorized signatory on behalf of the manufacturer

*N. Hadzidakis*

Name: N. E. Hadzidakis  
Title: Director  
N. Hadzidakis – T. Katsabakou Co.

## TABLE OF CONTENTS

1	INTRODUCTION .....	5
2	GENERAL DESCRIPTION .....	5
3	COMMUNICATION WITH THE USER .....	6
3.1	SERIAL PORT .....	6
3.2	SETTINGS.....	7
3.3	QUERIES .....	8
3.4	CONNECTION OF THE SERIAL PORT WITH GSM MODEM .....	9
4	PLACEMENT POSITIONS & CORRESPONDING OUTPUTS.....	9
5	TECHNICAL SPECIFICATIONS .....	11
5.1	ELECTRICAL CHARACTERISTICS .....	11
5.2	MECHANICAL CHARACTERISTICS.....	11
5.3	ENVIRONMENTAL CHARACTERISTICS .....	11
6	CONNECTING TO A DATA LOGGER.....	12
6.1	CONNECTIONS .....	12
6.2	SETTINGS.....	12

# 1 INTRODUCTION

The Tiltometer is a product for measuring the angle (verticality) of masts. The angle information will either be recorded on a data logger or will be monitored via the RS232 port, or both.

The Tiltometer is designed to watch the condition of mast by measuring its angle. As such, it allows you to:

- Communicate, via its serial port with a computer and obtain data as needed. You can change settings as you wish.
- Connect the Tiltometer with a data logger and record the measurements, which are provided as analog voltage outputs.
- Connect the serial port of the Tiltometer to a GSM Modem and have it send an SMS message to a preset number, if tilt angle exceeds a preset angle. This way a possible (and expensive) mast fall may be prevented.

The above operations are performed simultaneously with the sampling of measured data and without affecting their integrity.

# 2 GENERAL DESCRIPTION

According to the block diagram, shown in *Figure 1*, the Tiltometer has the following characteristics:

- Two voltage outputs, one for elevation angle and one for azimuth, with output range 0~2.5 volts or 0~5 volts. They can be connected as inputs to a data logger, PLC, etc.
- An RS232 port for local or remote (via GSM Modem) communication.
- The outputs update with frequency 2Hz, i.e. every 500ms.
- Power Supply: 6 to 15 VDC.
- It is calibrated and re-calibrated via software.

Analytic description of terminals is given in *Figure 2*.

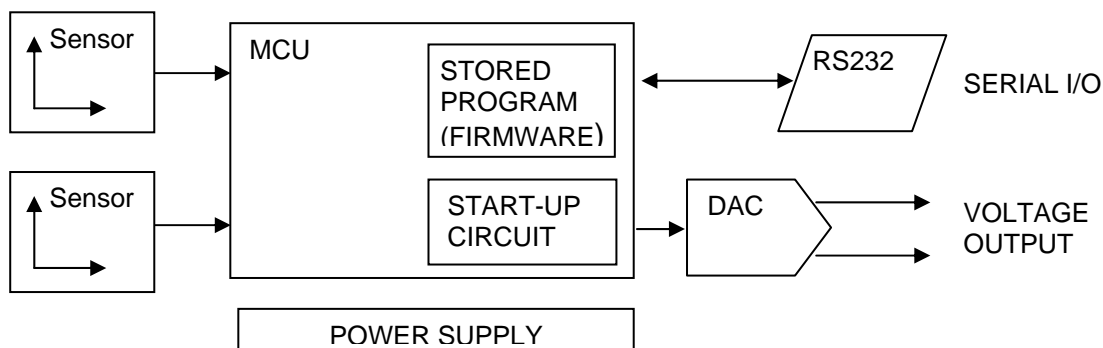

*Figure 1: General diagram*

*Figure 2: Description of the screw terminal*

10	9	8	7	6	5	4	3	2	1
----	---	---	---	---	---	---	---	---	---

- 1→ OUT AZIM: AZIMUTH OUTPUT, for connection to data logger.
- 2→ OUT ELEV: ELEVATION OUTPUT, for connection to data logger.
- 3→ AN. GND: OUTPUT GROUND
- 4→ Standard model (RS-232): RXD (Receive Data)  
Option (RS-422): RDA (-)
- 5→ Standard model (RS-232): TXD (Transmit Data)  
Option (RS-422): RDB (+)
- 6→ Standard model (RS-232): RTS (Request To Send)  
Option (RS-422): TDA (-)
- 7→ Standard model (RS-232): CTS (Clear To Send)  
Option (RS-422): TDB (+)
- 8→ S. GND: SERIAL GROUND
- 9→ BAT+12V: input supply
- 10→ BAT-: SUPPLY GROUND

## 3 COMMUNICATION WITH THE USER

### 3.1 SERIAL PORT

The Tiltometer has an RS232 serial port. It allows local set-up with a PC or data transfer.

Pin assignment:

- Pin 2 → Receive Data Line (RXD), the pin 4 of terminal (input)
- Pin 3 → Transmit Data Line (TXD), the pin 5 of terminal (output)
- Pin 5 → Ground, the pins 3, 8, 10 of terminal
- Pin 7 → Request To Send (RTS), the pin 6 of terminal (output)
- Pin 8 → Clear To Send (CTS), the pin 7 of terminal (input)

Communication speed is fixed at 9600 baud with 8 data bits, 1 stop bit, no parity bit. For communication between Tiltometer and PC connect a suitable cable and use the HyperTerminal software.

### 3.2 SETTINGS

i) **"!ALARMANGLE="**. Sets an alarm angle. The value is compared to the Elevation angle. If the Elevation angle becomes smaller than the ALARMANGLE then an SMS message with tilt information will be transmitted. The information may be exploited to prevent damage to an installation. Allowed values are from 0 to 89. For example: **"!ALARMANGLE=80"** etc. The value of 90 disables this feature. See also paragraph 3.4.

ii) **"!ALARMPHONE="**. This sets the phone number to send the SMS message. The phone number may be in local or international form (with country prefix), and up to 20 digits long. If both are registered and located in the same country enter the local form (for example, **"!ALARMPHONE=9876543210"**), otherwise enter the international form (for example, **"!ALARMPHONE=+309876543210"**, where the country's international prefix is 30)

iii) **"!RANGE="**. This command sets the output voltage range at 0~2.5 Volts (**"!RANGE=HALF"**) or 0~5 Volts (**"!RANGE=FULL"**). Output voltages represent angle; output 0 provides the elevation and output 1 provides the azimuth. The following figures show what you get with these settings.

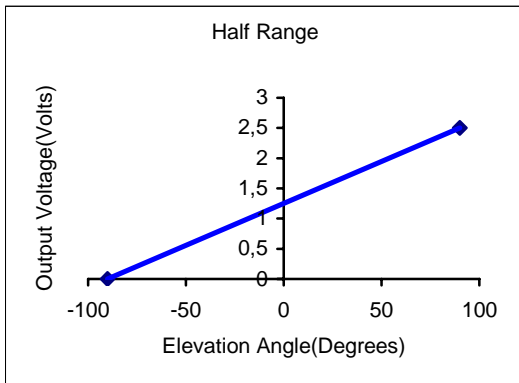

*Figure 3*

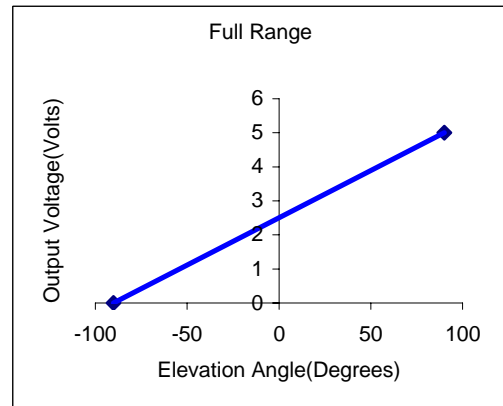

*Figure 5*

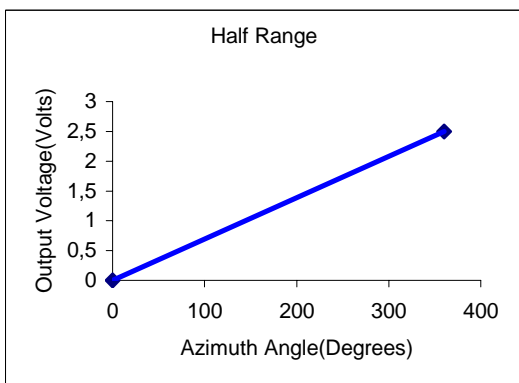

*Figure 4*

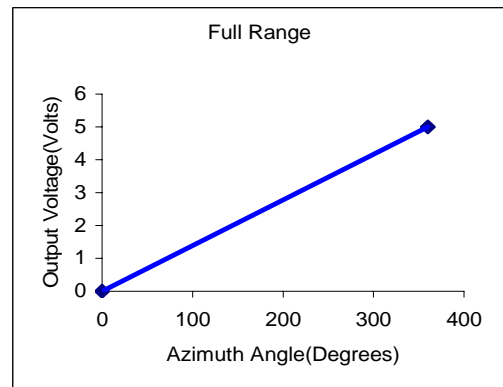

*Figure 6*

iv) **"!HANDSHAKE="**. This command sets the serial communication handshake options. The Tiltometer uses hardware control (RTS and CTS signals) when **"!HANDSHAKE=HARDWARE"**. The Tiltometer uses no handshake when you set **"!HANDSHAKE=NONE"**. You may want to use hardware handshake when, for instance, you want to inform a connected modem that the Tiltometer is about to transmit a message.

### 3.3 QUERIES

i) **"!ANGLE?"**. This command returns: ANGLE=E,A. Where E is the value of the elevation angle and is between -90 and 90 degrees and A is the value of the azimuth angle which is between 0 and 360 degrees.

ii) **"!START"**. This command starts sending a stream of angle pairs in the form E, A. The Tiltometer sends a new angle pair every 500 milliseconds.  
If this command is executed no other commands will be interpreted with the exception of the **"!STOP"** command.

iii) **"!STOP"**. It is used to stop the execution of the **!START** command.

iv) **"!ALARMANGLE?"**. This command returns: ALARMANGLE=y, where y is the angle which has been defined by the **"!ALARMANGLE="** command (see 3.2. Settings i)).

v) **"!ALARMPHONE?"**. Returns ALARMPHONE=N, where N is the number which we have defined by the command **"!ALARMPHONE="**(3.2. Settings ii)).

vi) **"!RANGE?"**. This command returns: RANGE =HALF or RANGE =FULL, according to its definition by the command **"!RANGE="**(see 3.2. Settings iii)).

vii) **"!HANDSHAKE?"**. This command returns the handshake options setting: HANDSHAKE =NONE or HANDSHAKE =HARDWARE, depending on the command **"!HANDSHAKE="**(see 3.2. Settings iv)).

viii) **"!STATUS?"**. This command returns:

TILTOMETER Vx.x

FIRMWARE Vx.x

UPTIME=k

ANGLE ALARMS=l

LAST ANGLE ALARM =n

The first line shows the hardware version number, the second is the firmware version number, the third is the time (k), in seconds, which has passed since the system is power up, the fourth is the number of angle alarms (l) generated since power up and the fifth is a number (n) representing the time the last angle alarm was generated in seconds, since power up.

- All settings and queries return OK or ERROR.
- All settings and queries must be terminated by the characters CR (ASCII 13 decimal) and LF (ASCII 10 decimal). If using HyperTerminal, make sure that you have checked the option *'Send Carriage Return characters along with Line Feeds'*.
- The Tiltometer does not echo back the characters it is receiving. This means that in order to see the commands you are typing in HyperTerminal, you must check the option *'Local echo of typed characters'*.

### 3.4 CONNECTION OF THE SERIAL PORT WITH GSM MODEM

Optionally, the Tiltometer may be connected to a GSM Modem via the serial port. You can use the serial connection through the modem for configuration or data acquisition.

Setting the ALARMANGLE parameter to a value less than 90, the alarm mechanism is activated. When the Elevation angle becomes smaller than the ALARMANGLE, then an SMS message to a preset number (ALARMPHONE) will be automatically send. Messages will be sent every 24 hours, until the Elevation angle increases above the ALARMANGLE value. If the alarm condition is removed before completion of the 24-hour interval, then an SMS will still be sent. The first SMS will not be sent until the power-up time is 24 hours. The SMS contains the following message:

*"Elevation Angle is X degrees. Alarm Angle is Y degrees. Dangerous Tilt!!! "*

where X is the current elevation angle and Y is the preset ALARMANGLE. GSM modems from Siemens and Wavecom have been tested and perform well with this function.

## 4 PLACEMENT POSITIONS & CORRESPONDING OUTPUTS

A general idea of the space in which the tiltometer can move and typical values of the elevation and azimuth angle are given in figure 7 (E: elevation, A: azimuth). Please notice that when Elevation is at 90 degrees, then the Azimuth cannot be determined; this is because the projection of the Z-axis on the horizontal plane becomes zero.

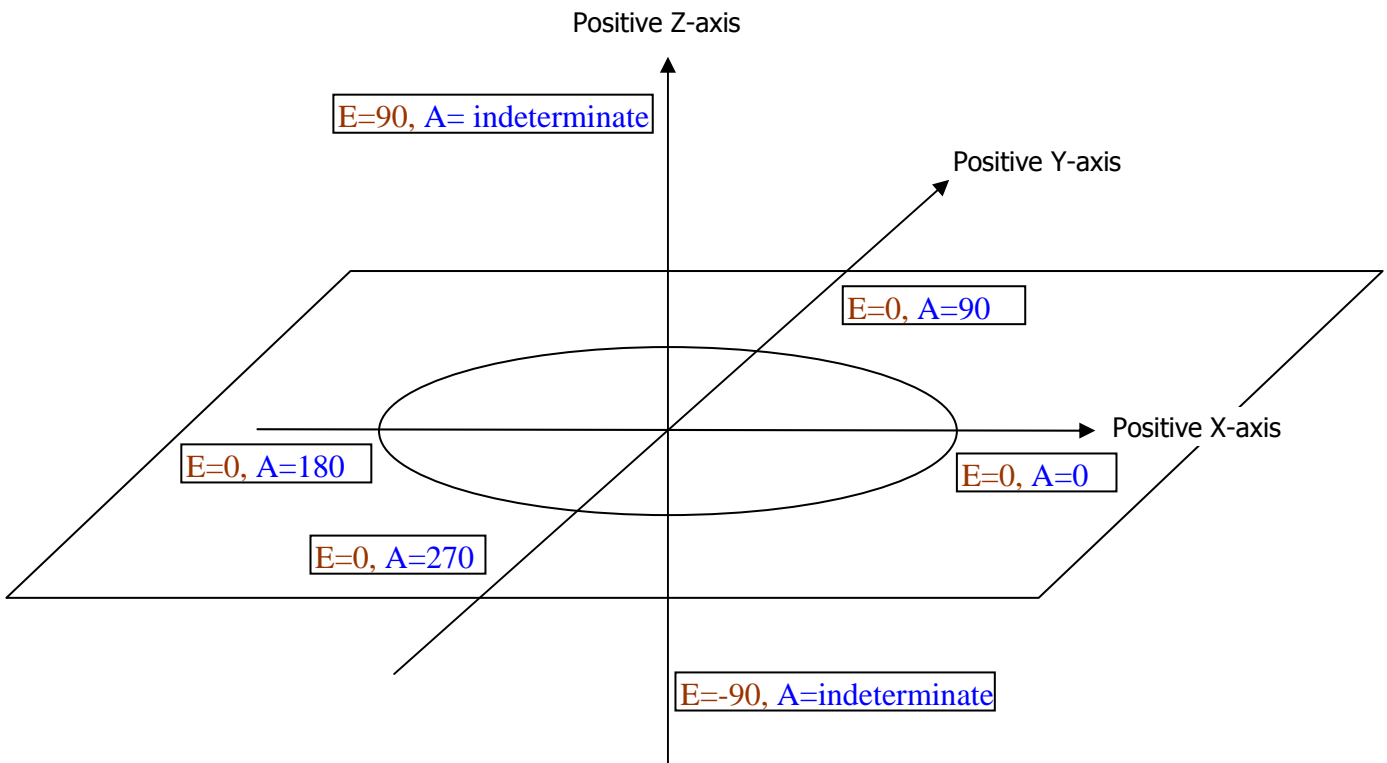

*Figure 7*

The following table summarizes the outputs versus basic positions.

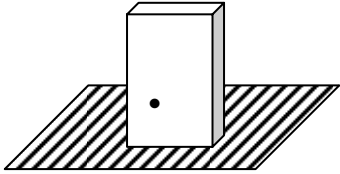
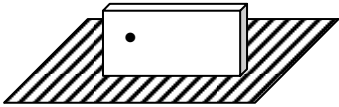
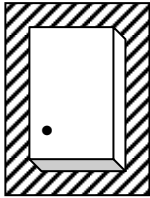
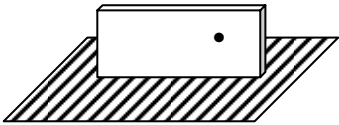
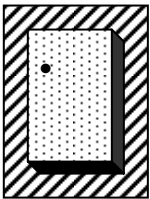
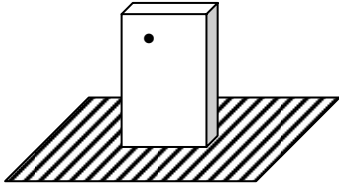
	<p>Absolute vertical position.</p> <ul style="list-style-type: none"> <li>• Elevation=90</li> <li>• Azimuth indeterminate</li> </ul>
	<ul style="list-style-type: none"> <li>• Elevation=0</li> <li>• Azimuth=90</li> </ul>
	<ul style="list-style-type: none"> <li>• Elevation=0</li> <li>• Azimuth=0 or 360</li> </ul>
	<ul style="list-style-type: none"> <li>• Elevation=0</li> <li>• Azimuth=270</li> </ul>
	<ul style="list-style-type: none"> <li>• Elevation=0</li> <li>• Azimuth=180</li> </ul>
	<ul style="list-style-type: none"> <li>• Elevation=-90</li> <li>• Azimuth indeterminate</li> </ul>

LEGEND

The symbol • indicates the screw terminal's position.

The hatch  indicates the horizontal level.

The symbol  indicates the **bottom** side of the Tiltometer.

## 5 TECHNICAL SPECIFICATIONS

### 5.1 ELECTRICAL CHARACTERISTICS

Please refer to *Figure 2*.

OUT AZIM: Output Azimuth.

- Range: 0-2.5 volts or 0-5 volts, representing 0 to +360 degrees.
- Resolution: 1,4 degrees.
- Accuracy: better than  $\pm 4$  degrees.
- Output update rate: 2 Hz.

OUT ELEV: Output Elevation.

- Range: 0-2.5 volts or 0-5 volts, representing  $-90$  to  $+90$  degrees.
- Resolution: 0,7 degrees.
- Accuracy: better than  $\pm 2$  degrees.
- Output Update Rate: 2 Hz.

Communication connection: 9600 baud, 8 bits, no parity.

PIN	Standard (RS-232)	Option (RS-422)
TXD	Output Transmit output	RDB (+) Input
RXD	Input Receive input	RDA (-) Input
RTS	Output ελέγχου ροής (handshake)	TDA (-) Output
CTS	Input ελέγχου ροής (handshake)	TDB (+) Output
S. GND	Serial Ground	Serial Ground

Step response (any value to final value): 8 seconds.

Power Supply: 6 to 15 VDC supply, 8 mA (typical).

### 5.2 MECHANICAL CHARACTERISTICS

- Connections of input and output: All user I/O connections are on internal 10-position screw terminal. Cable passes through IP65 PG7 gland.
- Box: Cast aluminium IP65.
- Dimensions: 115 x 65 x 30 mm.
- Mounting: directly on wind masts with diameters between 70 and 150mm, using clamp. This is possible if the 8 mm-high dome nuts (included) are used as shown in *Figure 8* (box's smallest side shown):

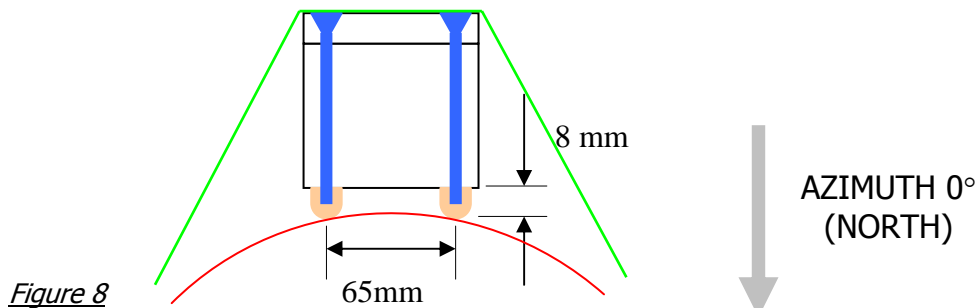

### 5.3 ENVIRONMENTAL CHARACTERISTICS

- Operating Temperature:  $-25$  to  $+75$  °C.
- Protection: IP65.

## 6 CONNECTING TO A DATA LOGGER

### 6.1 CONNECTIONS

TILTOMETER	GENERIC DATA LOGGER	STYLITIS-41	STYLITIS-101 <sup>(1)</sup>	BATTERY
Screw #10 BAT-	-	-	-	BAT -
Screw #9 BAT+12V	-	-	-	BAT +
Screw #1 AZIMUTH	ANALOG CHANNEL	ANY ANALOG IN	ANY ANALOG IN	-
Screw #2 ELEVATION	ANALOG CHANNEL	ANY ANALOG IN	ANY ANALOG IN	-
Screw #3 AN. GND	ANALOG GROUND	GROUND	GROUND	-

### 6.2 SETTINGS

These settings deliver recorded values from 0 to 360 degrees for azimuth and from -90 to 90 degrees for elevation:

Data loggers with a 0 to 5V input range:

	AZIMUTH	ELEVATION
SLOPE	72.0	36.0
OFFSET	0.0	-90.0

Data loggers with a 0 to 2.5V input range <sup>(2)</sup>:

	AZIMUTH	ELEVATION
SLOPE	144.0	72.0
OFFSET	0.0	-90.0

#### **NOTES:**

(1) On Stylitis-101, connect the AN [-] inputs to the GND on the screw terminal. Set the input range to 0~5V, Unipolar.

(2) For data loggers with input range equal to 0~2.5V, use the RS232 port to set the Tiltometer's output range to half. Issue the command: !RANGE=HALF (See 3.2).

(3)